

INSTRUCTIONS–PARTS LIST



This manual contains important warnings and information.
READ AND RETAIN FOR REFERENCE

INSTRUCTIONS

819.6900

Rev. J

Air-Operated Diaphragm Pumps

100 psi; 0.7 MPa; 7 bar Maximum Fluid Working Pressure

100 psi; 0.7 MPa; 7 bar Maximum Air Input Pressure

ACETAL, POLYPROPYLENE, AND KYNAR®

VERDERAIR VA 15

ALUMINUM AND STAINLESS STEEL

VERDERAIR VA 20

Refer to the Pump Listing on page 20 to determine the Model No. of your pump.

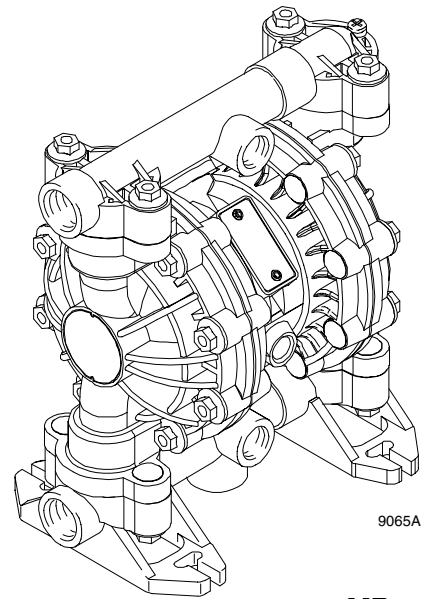

9065A

VERDERAIR VA 15

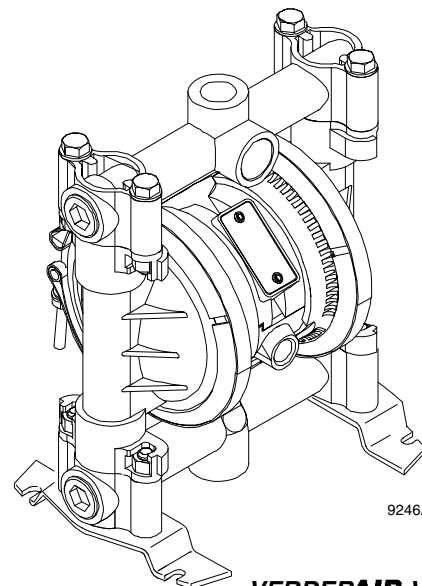

9246A

VERDERAIR VA 20



Table of Contents

Safety Warnings	2
Installation	4
Operation	10
Maintenance	11
Troubleshooting	12
Service	13
<i>VERDERAIR VA 15 and VERDERAIR VA 20</i>	
Pump Listing	20
<i>VERDERAIR VA 15 and VERDERAIR VA 20</i>	
Repair Kits	22
Parts	
<i>VERDERAIR VA 15 and VERDERAIR VA 20</i>	
Common Parts	23
<i>VERDERAIR VA 15</i> Parts Drawing	24
<i>VERDERAIR VA 15</i> Fluid Section Parts List	25
<i>VERDERAIR VA 20</i> Parts Drawing	26
<i>VERDERAIR VA 20</i> Fluid Section Parts List	27
VERDERAIR VA 15:	
Technical Data	28
Dimensions	29
VERDERAIR VA 20:	
Technical Data	30
Dimensions	31
<i>VERDERAIR VA 15 and VERDERAIR VA 20</i>	
Performance Charts	32
VERDER Standard Warranty	34

Symbols

Warning Symbol



This symbol alerts you to the possibility of serious injury or death if you do not follow the instructions.

Caution Symbol



This symbol alerts you to the possibility of damage to or destruction of equipment if you do not follow the instructions.

Warning



INSTRUCTIONS

EQUIPMENT MISUSE HAZARD

Equipment misuse can cause the equipment to rupture or malfunction and result in serious injury.

- This equipment is for professional use only.
- Read all instruction manuals, tags, and labels before operating the equipment.
- Use the equipment only for its intended purpose. If you are not sure, call your VERDER distributor.
- Do not alter or modify this equipment. Use only genuine VERDER parts and accessories.
- Check equipment daily. Repair or replace worn or damaged parts immediately.
- Do not exceed the maximum working pressure of the lowest rated component in your system. This equipment has a **100 psi; 0.7 MPa (7 bar) maximum working pressure at 100 psi; 0.7 MPa (7 bar) maximum incoming air pressure.**
- Use fluids and solvents that are compatible with the equipment wetted parts. Refer to the **Technical Data** section of all equipment manuals. Read the fluid and solvent manufacturer's warnings.
- Route hoses away from traffic areas, sharp edges, moving parts, and hot surfaces. Do not expose VERDER hoses to temperatures above 180°F (82°C) or below -40°C (-40°C).
- Wear hearing protection when operating this equipment.
- Do not lift pressurized equipment.
- Comply with all applicable local, state, and national fire, electrical, and safety regulations.
- Do not use 1.1.1-trichloroethane, methylene chloride, other halogenated hydrocarbon solvents or fluids containing such solvents in pressurized aluminum equipment. Such use could result in a chemical reaction, with the possibility of explosion.

Warning



TOXIC FLUID HAZARD

Hazardous fluid or toxic fumes can cause serious injury or death if splashed in the eyes or on the skin, inhaled, or swallowed.



- Know the specific hazards of the fluid you are using.
- Do not lift a pump under pressure. If dropped, the fluid section may rupture. Always follow the **Pressure Relief Procedure** on page 10 before lifting the pump.
- Store hazardous fluid in an approved container. Dispose of hazardous fluid according to all local, state, and national guidelines.
- Always wear protective eyewear, gloves, clothing, and respirator as recommended by the fluid and solvent manufacturer.
- Pipe and dispose of the exhaust air safely, away from people, animals, and food handling areas. If the diaphragm fails, the fluid is exhausted along with the air. Read **Air Exhaust Ventilation** on page 6.
- **Never** use an acetal pump to pump acids. Take precautions to avoid acid or acid fumes from contacting the pump housing exterior. Stainless steel parts will be damaged by exposure to acid spills and fumes.



FIRE AND EXPLOSION HAZARD

Improper grounding, poor ventilation, open flames, or sparks can cause a hazardous condition and result in a fire or explosion and serious injury.



- Ground the equipment. Refer to **Grounding** on page 8.
- **Never** use a polypropylene or Kynar® pump with non-conductive flammable fluids as specified by your local fire protection code. Refer to **Grounding** on page 8 for additional information. Consult your fluid supplier to determine the conductivity or resistivity of your fluid.
- If there is any static sparking or you feel an electric shock while using this equipment, **stop pumping immediately**. Do not use the equipment until you identify and correct the problem.
- Provide fresh air ventilation to avoid the buildup of flammable fumes from solvents or the fluid being pumped.
- Pipe and dispose of the exhaust air safely, away from all sources of ignition. If the diaphragm fails, the fluid is exhausted along with the air. Read **Air Exhaust Ventilation** on page 6.
- Keep the work area free of debris, including solvent, rags, and gasoline.
- Electrically disconnect all equipment in the work area.
- Extinguish all open flames or pilot lights in the work area.
- Do not smoke in the work area.
- Do not turn on or off any light switch in the work area while operating or if fumes are present.
- Do not operate a gasoline engine in the work area.

Installation

General Information

- The Typical Installations in Fig. 2 are only guides for selecting and installing system components. Contact your VERDER distributor for assistance in planning a system to suit your needs.
- Always use Genuine VERDER Parts and Accessories.
- Use a compatible, liquid thread sealant on all male threads. Tighten all connections firmly to avoid air or fluid leaks.

Tightening Threaded Fasteners Before First Use

After unpacking the pump, and before using it for the first time, check and retorque all external fasteners. See the **Service** section for torque specifications. After the first day of operation, retorque the fasteners again. Although the recommended frequency for retorquing fasteners varies with pump usage, a general guideline is to retorque fasteners every two months.

Toxic Fluid Hazard

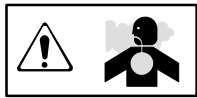

Read **Toxic Fluid Hazard** on page 3.

Use fluids and solvents that are compatible with the equipment wetted parts. Refer to the **Technical Data** section of all equipment manuals. Read the fluid and solvent manufacturer's warnings.

Caution

Safe Operating Temperatures

Minimum (all pumps): 40° F (4° C)

Maximum

Acetal: 180° F (82° C)

Polypropylene: 150° F (66° C)

Aluminum, stainless steel, Kynar®: 225° F (107° C)

These temperatures are based upon mechanical stress only and may be significantly altered by pumping certain chemicals. Consult engineering guides for chemical compatibilities and temperature limits, or contact your VERDER distributor.

Mountings

- These pumps can be used in a variety of installations. Be sure the mounting surface can support the weight of the pump, hoses, and accessories, as well as the stress caused during operation.
- Fig. 2 shows some installation examples. On all installations, mount the pump using screws and nuts.

Pumping High-Density Fluids

High density fluids may prevent the lighter non-metallic check valve balls from seating properly, which reduces pump performance significantly. Stainless steel balls should be used for such applications.

Installation

Air Line

Warning

A bleed-type master air valve (B) is required in your system to relieve air trapped between this valve and the pump. See Fig. 2. Trapped air can cause the pump to cycle unexpectedly, which could result in serious injury, including splashing in the eyes or on the skin, injury from moving parts, or contamination from hazardous fluids.

Caution

The pump exhaust air may contain contaminants. Ventilate to a remote area if the contaminants could affect your fluid supply. Read Air Exhaust Ventilation on page 6.

1. Install the air line accessories as shown in Fig. 2. Mount these accessories on the wall or on a bracket. Be sure the air line supplying the accessories is electrically conductive.
 - a. The fluid pressure can be controlled in either of two ways. To control it on the air side, install an air regulator (G). To control it on the fluid side, install a fluid regulator (J) near the pump fluid outlet (see Fig. 2).
 - b. Locate one bleed-type master air valve (B) close to the pump and use it to relieve trapped air. Read the **Warning** above. Locate the other master air valve (E) upstream from all air line accessories and use it to isolate them during cleaning and repair.
 - c. The air line filter (F) removes harmful dirt and moisture from the compressed air supply.
2. Install an electrically conductive, flexible air hose (C) between the accessories and the 1/4 npt(f) pump air inlet. Use a minimum 1/4 in. ID air hose. Screw an air line quick disconnect coupler (D) onto the end of the air hose (C), and screw the mating fitting into the pump air inlet snugly. Do not connect the coupler (D) to the fitting yet.

Installation of Remote Pilot Airlines

1. Connect the air line to the pump as noted above.
2. Connect 1/4 OD tubing to the push type connectors (16) on the underside of the pump.

NOTE: By replacing the push type connectors, other sizes or types of fittings may be used. The new fittings will require 1/8 in. NPT threads.

3. Connect the other end of the tubes to the external air signal, such as VERDER's Cycleflo (PN 819.9742) or Cycleflo II (819.9743) controllers.

NOTE: The air pressure at the connectors must be at least 30% of the air pressure to the airmotor for the pump to operate.

Fluid Suction Line

- If using a conductive (acetal) pump, use conductive hoses. If using a non-conductive pump, ground the fluid system. Read **Grounding** on page 8. The fluid inlet port is 1/2 in. or 3/4 in..
- At inlet fluid pressures greater than 15 psi; 0.1 MPa (1 bar), diaphragm life will be shortened.

Fluid Outlet Line

Warning

A fluid drain valve (H) is required in your system to relieve pressure in the hose if it is plugged. See Fig. 2. The drain valve reduces the risk of serious injury, including splashing in the eyes or on the skin, or contamination from hazardous fluids when relieving pressure. Install the valve close to the pump fluid outlet.

1. Use electrically conductive fluid hoses (K). The pump fluid outlet is 1/2 in. or 3/4 in. Screw the fluid fitting into the pump outlet snugly. **Do not overtighten.**
2. Install a fluid regulator (J) at the pump fluid outlet to control fluid pressure, if desired (see Fig. 2). See **Air Line**, step 1a., for another method of controlling pressure.
3. Install a fluid drain valve (H) near the fluid outlet. Read the **warning** above.

Installation



Fluid Pressure Relief Valve

Caution

Some systems may require installation of a pressure relief valve at the pump outlet to prevent overpressurization and rupture of the pump or hose. See Fig. 1.

Thermal expansion of fluid in the outlet line can cause overpressurization. This can occur when using long fluid lines exposed to sunlight or ambient heat, or when pumping from a cool to a warm area (for example, from an underground tank).

Overpressurization can also occur if the *VERDERAIR* pump is being used to feed fluid to a piston pump, and the intake valve of the piston pump does not close, causing fluid to back up in the outlet line.

-  Install valve between fluid inlet and outlet ports.
-  Connect fluid inlet line here.
-  Connect fluid outlet line here.

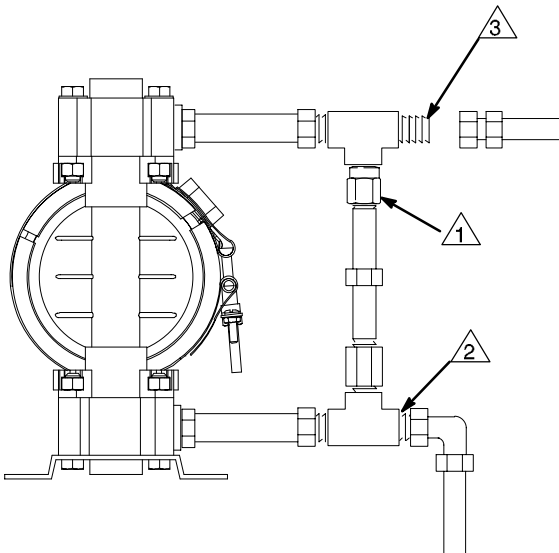

Fig. 1

9073A

Air Exhaust Ventilation



Read **Toxic Fluid Hazard** on page 3.



Read **Fire and Explosion Hazard** on page 3.

Be sure the system is properly ventilated for your type of installation. You must vent the exhaust to a safe place, away from people, animals, food handling areas, and all sources of ignition when pumping flammable or hazardous fluids.

Diaphragm failure will cause the fluid being pumped to exhaust with the air. Place an appropriate container at the end of the air exhaust line to catch the fluid. See Fig. 2.

The air exhaust port is 3/8 npt(f). Do not restrict the air exhaust port. Excessive exhaust restriction can cause erratic pump operation.

See **Venting Exhaust Air** in Fig. 2. Exhaust to a remote location as follows:

1. Remove the muffler (W) from the pump air exhaust port.
2. Install an electrically conductive air exhaust hose (X) and connect the muffler to the other end of the hose. The minimum size for the air exhaust hose is 3/8 in.(10 mm) ID. If a hose longer than 15 ft (4.57 m) is required, use a larger diameter hose. Avoid sharp bends or kinks in the hose.
3. Place a container (Z) at the end of the air exhaust line to catch fluid in case a diaphragm ruptures. See Fig. 2.

Installation

ABOVE-GROUND TRANSFER INSTALLATION

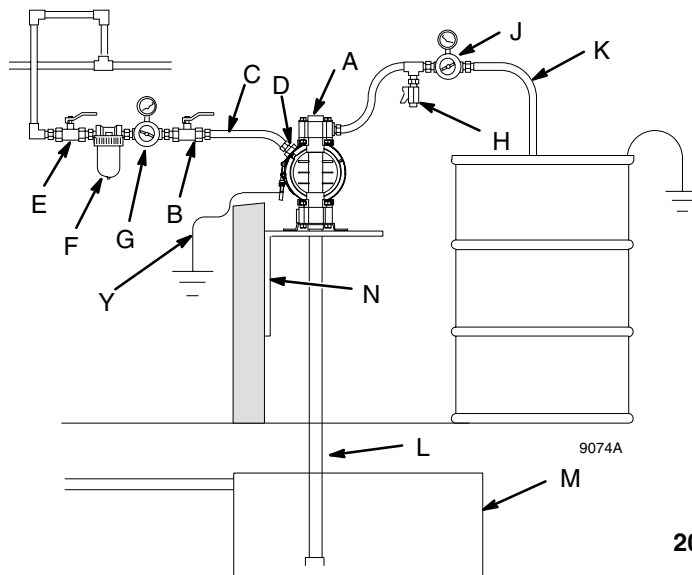

KEY

- A Pump
- B Bleed-type master air valve (required for pump)
- C Electrically conductive air supply line
- D Air line quick disconnect
- E Master air valve (for accessories)
- F Air line filter
- G Pump air regulator
- H Fluid drain valve (required)
- J Fluid regulator (optional)
- K Electrically conductive fluid supply hose
- L Fluid suction line
- M Underground storage tank
- N Wall mounting bracket
- Y Ground wire (required; see page 8 for installation instructions)

208-LITER BUNG PUMP INSTALLATION

KEY

- A Pump
- C Electrically conductive air supply line
- D Air line quick disconnect
- H Fluid drain valve (required)
- K Electrically conductive fluid supply hose
- L Fluid suction line
- Y Ground wire (required; see page 8 for installation instructions)

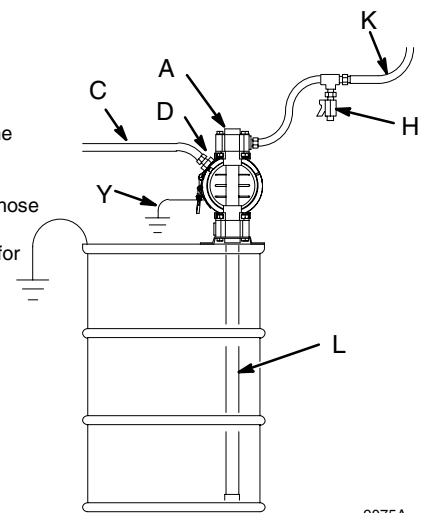

AIR SPRAY INSTALLATION

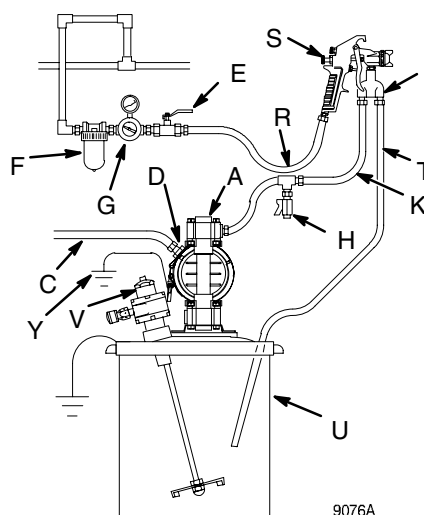

KEY

- A Pump
- C Electrically conductive air line to pump
- E Gun air line shutoff valve
- F Air line filter
- G Gun air regulator
- H Fluid drain valve (required)
- K Electrically conductive fluid supply hose
- P Circulating valve
- R Electrically conductive air line to gun
- S Air spray gun
- T Electrically conductive fluid return line
- U 19-liter pail
- V Agitator
- Y Ground wire (required; see page 8 for installation instructions)

KEY

- W Muffler
- X Electrically Conductive Air Exhaust Hose
- Z Container for Remote Air Exhaust

All wetted and non-wetted pump parts must be compatible with the fluid being pumped.

VENTING EXHAUST AIR

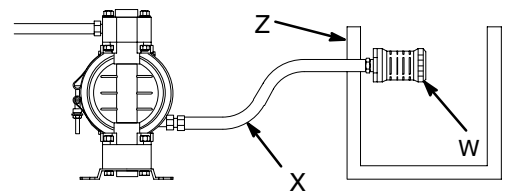

Fig. 2

04054

Installation

Grounding

Warning



FIRE AND EXPLOSION HAZARD

This pump must be grounded. Before operating the pump, ground the system as explained below. Also read the section **Fire and Explosion Hazard** on page 3.



The *acetal VERDERAIR VA 15 pump* contains stainless steel fibers, which makes the wetted parts conductive. Attaching the ground wire to

the grounding screw (106) grounds the wetted parts. See **grounding screw** on page 24.

The *metal VERDERAIR VA 20 pumps* have a grounding strip connecting the vee clamps (109). Attach a ground wire to the grounding strip with the screw, lockwasher, and nut as shown in the **Grounding Detail** on page 26.

The *polypropylene and Kynar® VERDERAIR VA 15 pumps* are **not** conductive.

When pumping conductive flammable fluids, **always** ground the entire fluid system by making sure the fluid system has an electrical path to a true earth ground (see Fig. 3). **Never** use a polypropylene or Kynar® pump with non-conductive flammable fluids as specified by your local fire protection code.

US Code (NFPA 77 Static Electricity) recommends a conductivity greater than 50×10^{-12} Siemens/meter (ohms/meter) over your operating temperature range to reduce the hazard of fire. Consult your fluid supplier to determine the conductivity or resistivity of your fluid. The resistivity must be less than 2×10^{12} ohm-centimeters.

To reduce the risk of static sparking, ground the pump and all other equipment used or located in the pumping area. Check your local electrical code for detailed grounding instructions for your area and type of equipment.

NOTE: When pumping conductive flammable fluids with a polypropylene or Kynar® pump, **always** ground the fluid system. See the **warning** above. Fig. 3 shows a recommended method of grounding flammable fluid containers during filling.

Ground all of this equipment:

- **Pump:** The metal pump has a grounding strip in front of the center housing. The acetal pump has a grounding screw on the top manifold. Connect the non-clamp end of the ground wire to the grounding strip or grounding screw, and connect the clamp end of the ground wire to a true earth ground. To order a ground wire and clamp, order Part No. 819.0157.
- **Air and fluid hoses:** Use only electrically conductive hoses.
- **Air compressor:** Follow the manufacturer's recommendations.
- **Solvent pails used when flushing:** Follow the local code. Use only grounded metal pails, which are conductive. Do not place the pail on a non-conductive surface, such as paper or cardboard, which interrupts the grounding continuity.
- **Fluid supply container:** Follow the local code.

GROUNDING A PUMP

KEY

- A Pump
- H Fluid drain valve (required)
- S Dispense valve
- T Fluid drain line
- Y Fluid section grounding via grounding strip or grounding screw (required for metal and acetal pumps)
- Z Container ground wire (required)



Hose must be conductive.



Dispense valve nozzle must be in contact with container.

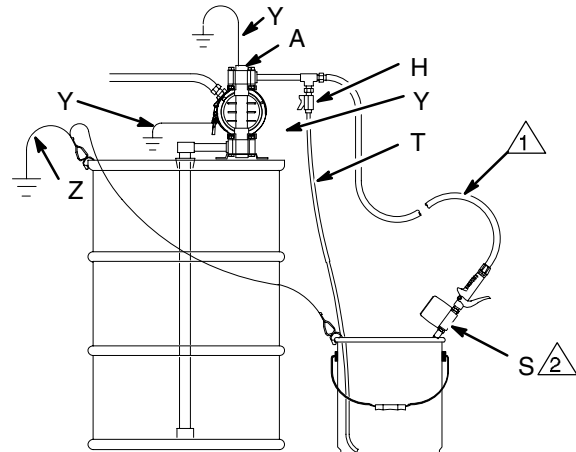

Fig. 3

9079A

Installation

Changing the Orientation of the Fluid Inlet and Outlet Ports (*VERDERAIR VA 15*)

You can change the orientation of the fluid inlet and outlet ports by repositioning the manifolds. For *VERDERAIR VA 15*, see Fig. 4. For *VERDERAIR VA 20*, see Fig. 5.

1. Remove the four manifold nuts (109) or bolts (105).
2. Turn the manifold to the desired position, reinstall the nuts or bolts, and torque to 80 to 90 in-lb (9 to 10 N.m).

NOTE: Make sure all manifold o-rings are positioned correctly before you fasten the manifold. Manifold o-rings (139) are shown in Fig. 7 and Fig. 8.

NOTE: Pumps with duckbill check valves are shipped with the inlet manifold on top and the outlet manifold on the bottom. See page 14 for details.

 Torque to 80 to 90 in-lb (9 to 10 N.m).

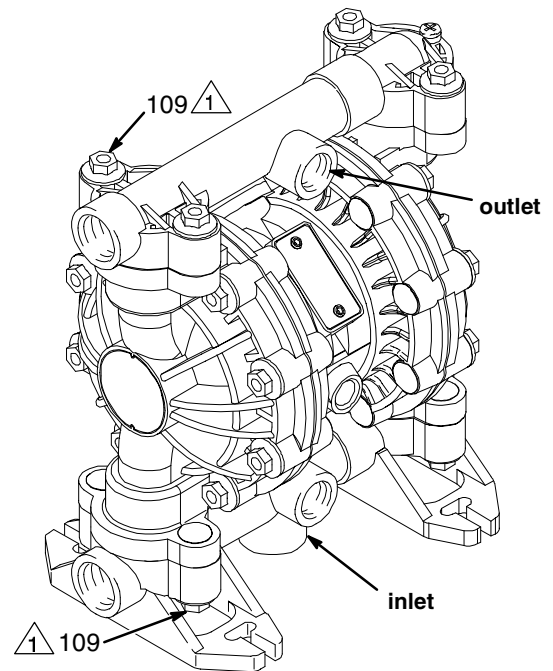



Fig. 4

9065A

 Torque to 80 to 90 in-lb (9 to 10 N.m).

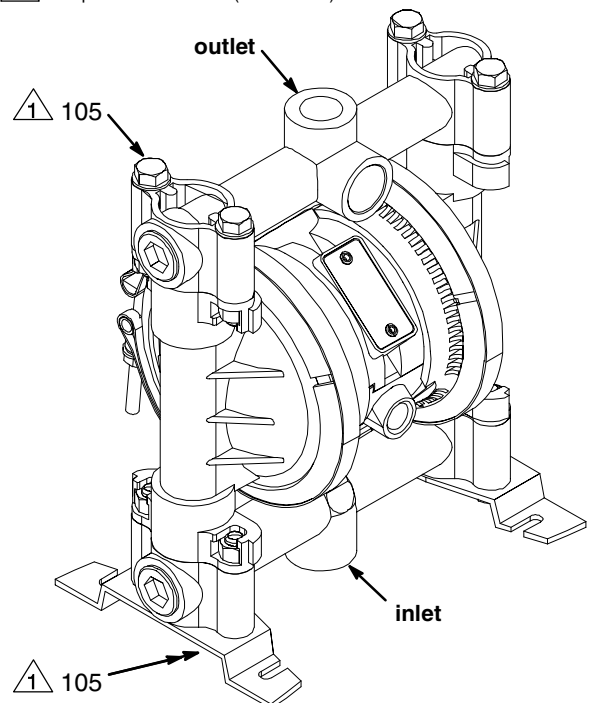

Fig. 5

9071A

Operation

Pressure Relief Procedure

Warning

PRESSURIZED EQUIPMENT HAZARD







The equipment stays pressurized until pressure is manually relieved. To reduce the risk of serious injury from pressurized fluid, accidental spray, or splashing fluid, follow this procedure whenever you:

- Are instructed to relieve pressure;
 - Stop pumping;
 - Check, clean or service any system equipment;
 - Install or clean fluid nozzles.
1. Shut off the air to the pump.
 2. Open the dispensing valve, if used.
 3. Open the fluid drain valve to relieve all fluid pressure, and have a container ready to catch the drainage.

Flush the Pump Before First Use

The pump was tested in water. Prior to use, flush the pump thoroughly with a compatible solvent. Follow the steps under **Starting and Adjusting the Pump**.

Starting and Adjusting the Pump

1.   Read **Toxic Fluid Hazard** on page 3.
2.  If lifting the pump, follow the **Pressure Relief Procedure** above.
3.    Be sure the pump is properly grounded. Read **Fire and Explosion Hazard** on page 3.

4. Check all fittings to be sure they are tight. Use a compatible liquid thread sealant on all male threads. Tighten the fluid inlet and outlet fittings snugly. Do not overtighten the fittings into the pump.
 5. Place the suction tube (if used) in the fluid to be pumped.
- NOTE:** If the inlet fluid pressure to the pump is more than 25% of the outlet working pressure, the ball check valves will not close fast enough, resulting in inefficient pump operation.
6. Place the end of the fluid hose (K) into an appropriate container.
 7. Close the fluid drain valve (H).
 8. With the pump air regulator (G) closed, open all bleed-type master air valves (B, E).
 9. If the fluid hose has a dispensing device, hold it open while continuing with the following step. Slowly open the air regulator (G) until the pump starts to cycle. Allow the pump to cycle slowly until all air is pushed out of the lines and the pump is primed.

If you are flushing, run the pump long enough to thoroughly clean the pump and hoses. Close the air regulator. Remove the suction tube from the solvent and place it in the fluid to be pumped.

Operation of Remote Piloted Pumps

1. Follow steps 1–8 above.
2. Open the air regulator (G).

Warning

The pump may cycle once before the external signal is applied.

3. The pump will operate when air pressure is alternately applied to the push type connectors (16).

NOTE: Leaving air pressure applied to the air motor for extended periods when the pump is not running may shorten the diaphragm life. Using a 3-way solenoid valve to automatically relieve the pressure on the airmotor when the metering cycle is complete prevents this from occurring.

Pump Shutdown

 At the end of the work shift, **relieve the pressure** as described in **Pressure Relief Procedure** at left.

Maintenance

Lubrication

The air valve is lubricated at the factory to operate without additional lubrication. If you want to provide additional lubrication, remove the hose from the pump air inlet and add two drops of machine oil to the air inlet every 500 hours of operation or every month.



Do not over-lubricate the pump. Oil is exhausted through the muffler, which could contaminate your fluid supply or other equipment. Excessive lubrication can also cause the pump to malfunction.

Flushing and Storage

Flush the pump to prevent the fluid you are pumping from drying or freezing in the pump and damaging it. Use a compatible solvent.

Always flush the pump and **relieve the pressure** before you store it for any length of time.



Read **Pressure Relief Procedure** on page 10.

Tightening Threaded Connections

Before each use, check all hoses for wear or damage and replace as necessary. Check to be sure all threaded connections are tight and leak-free.

Check and retorque all threaded connections, including manifold screws, clamps, and air valve screws, at least every two months. Although the recommended frequency for retorquing of fasteners varies with pump usage, a general guideline is to retorque every two months.

Preventive Maintenance Schedule

Establish a preventive maintenance schedule, based on the pump's service history. This is especially important for prevention of spills or leakage due to diaphragm failure.

Troubleshooting



Read **Pressure Relief Procedure** on page 10, and **relieve the pressure** before you check or service the equipment. Check all possible problems and causes before disassembling the pump.

PROBLEM	CAUSE	SOLUTION
Pump will not cycle, or cycles once and stops.	Air valve is stuck or dirty.	Use filtered air.
Pump cycles at stall or fails to hold pressure at stall.	Leaky check valves or o-rings.	Replace.
	Worn check balls or duckbill valves or guides.	Replace.
	Check ball wedged in guide.	Repair or replace.
	Worn diaphragm shaft seals.	Replace.
Pump operates erratically.	Clogged suction line.	Inspect; clear.
	Sticky or leaking check valve balls.	Clean or replace.
	Diaphragm ruptured.	Replace.
Air bubbles in fluid.	Suction line is loose.	Tighten.
	Diaphragm ruptured.	Replace.
	Loose manifolds or damaged manifold o-rings.	Tighten manifold bolts or nuts; replace o-rings.
	Loose fluid side diaphragm plates.	Tighten.
Fluid in exhaust air.	Diaphragm ruptured.	Replace.
	Loose fluid side diaphragm plates.	Tighten.
	Worn diaphragm shaft seals.	Replace.
Pump exhausts air from clamps (metal pumps).	Loose clamps.	Tighten clamp nuts.
	Air valve o-ring is damaged.	Inspect; replace.
Pump leaks fluid from check valves.	Worn or damaged check valve o-rings.	Inspect; replace.

Service

Air Valve (VERDERAIR VA 15 and VERDERAIR VA 20 Pumps)

NOTE: Air Valve Repair Kit 819.6898 is available. Parts included in the kit are marked with a dagger (†) in Fig. 6 and in the Parts Drawings and Lists. A tube of general purpose grease 819.0184 is supplied in the kit. Service the air valve as follows. See Fig. 6.



1. **Relieve the pressure.** See **Pressure Relief Procedure** on page 10.

2. Remove the cover (10) and the o-ring (4).
3. Remove the carriage plungers (7), carriages (8), carriage pins (9), and valve plate (14) from the center housing (11).

4. Clean all the parts, and inspect them for wear or damage.

NOTE: If you are installing the new Air Valve Repair Kit 819.6898, use all the parts in the kit.

5. Grease the lapped surface of the valve plate (14), and install the valve plate with the lapped surface facing up.
6. Grease the bores of the center housing (11), install the u-cup packings (2) on the carriage plungers (7), and slide the carriage plungers into the carriage plunger bores. See the following important installation notes:

NOTES:

- When you install each u-cup packing (2) on each carriage plunger (7), make sure the lips of the u-cup packing face toward the **clip end** (the smaller end) of the carriage plunger.
 - When you slide the carriage plungers (7) into the bores, slide them in with the clip ends (the smaller ends) facing toward the center of the center housing (11).
7. Grease the carriage pins (9), and slide the carriage pins into the carriage pin bores.
 8. Install the carriages (8). Make sure the carriages engage the clip ends of the carriage plungers (7) and carriage pins (9).
 9. Grease the o-ring (4), and seat it in the groove around the cover opening of the center housing (11).
 10. Screw cover (10) into center housing, and torque cover from 80 to 100 in-lb (9.0 to 13.6 N•m).

NOTE: Center housing (11) is shown separated from the air covers, but it is not necessary to remove the air covers for this service. Leave the center housing and air covers assembled for this service.

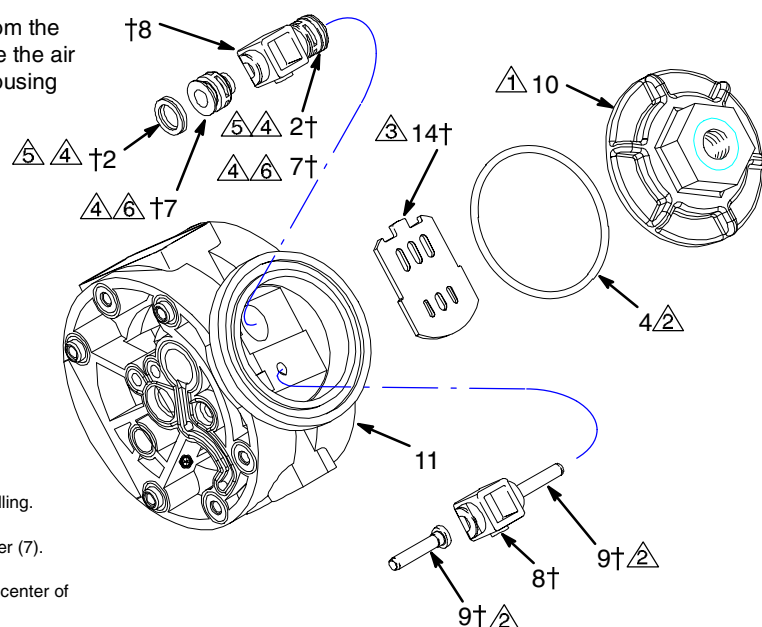

† Included in Air Valve Repair Kit 819.6898.

1. Torque to 80 to 100 in-lb (9.0 to 13.6 N•m).
2. Apply grease.
3. Apply grease to lapped face.
4. Apply grease to bores of center housing (11) before installing.
5. Seal lips face clip end (the smaller end) of carriage plunger (7).
6. Install with the clip ends (the smaller ends) facing toward center of center housing (11).

Fig. 6

9069A

Service

Ball or Duckbill Check Valves

NOTE: Fluid Section Repair Kit is available. See page 22 to order the correct kit for your pump. Parts included in the kit are marked with a double dagger (‡) in Fig. 7 and Fig. 8 and in the Parts Drawings and Lists. General purpose grease 819.0184 and Adhesive 819.9741 are supplied in the kit.



1. **Relieve the pressure.** See **Pressure Relief Procedure** on page 10.

2. Remove the top and bottom manifolds (102, 103).
3. Remove all parts shown with a dagger (‡) in Fig. 7 and Fig. 8.
4. Clean all parts, and replace worn or damaged parts.
5. Reassemble the pump.

NOTE: Torque the manifold nuts (109) or bolts (105) to 80 to 90 in-lb (9 to 10 N.m).

Inlet and Outlet for Pumps with Duckbill Check Valves

Pumps with duckbill check valves are shipped with the inlet manifold on top and the outlet manifold on the bottom. To make the inlet manifold on the bottom and the outlet manifold on the top, rotate each of the four duckbill assemblies vertically 180° as shown below.

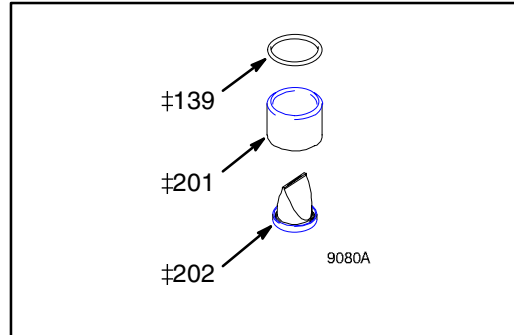

Service

VERDERAIR VA 15

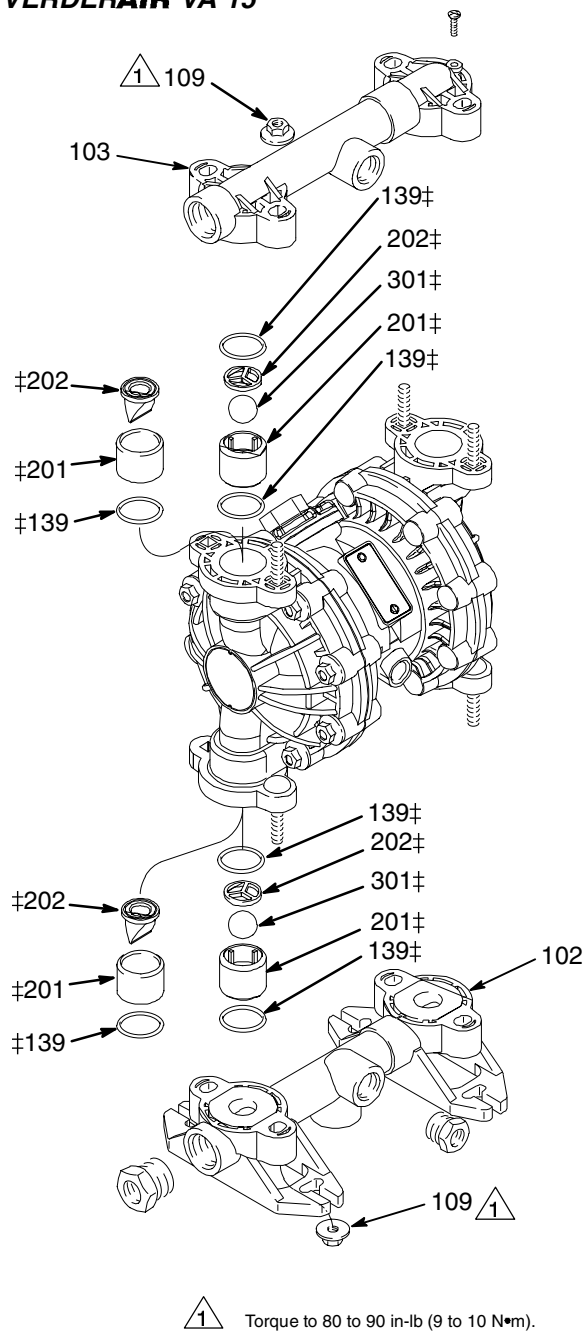

Fig. 7

9067A

VERDERAIR VA 20

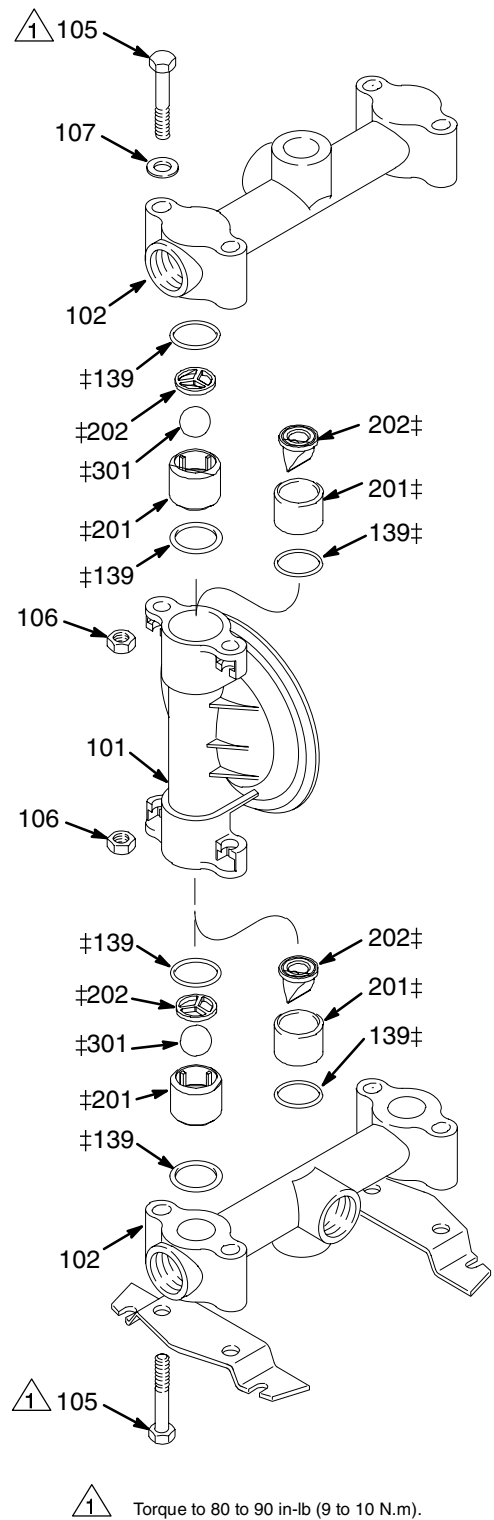

Fig. 8

9081A

Service

Diaphragms (VERDERAIR VA 15)

NOTE: Fluid Section Repair Kit is available. See page 22 to order the correct kit for your pump. Parts included in the kit are marked with a double dagger (‡) in Fig. 9 and in the Parts Drawings and Lists. General purpose grease 819.0184 and Adhesive 819.9741 are supplied in the kit. Service the diaphragms as follows. See Fig. 9.

Disassembly



1. **Relieve the pressure.** See **Pressure Relief Procedure** on page 10.

2. Remove manifolds (102 and 103) and fluid covers (101).

NOTE: Make sure all the check valve parts stay in place. See Fig. 7 on page 15.

3. Remove one of the fluid-side diaphragm plates (105) (whichever one comes loose first when you use a wrench on the hex of each), and pull the diaphragm shaft out of the center housing (11).
4. Use a wrench on the flats of the diaphragm shaft (15) to remove the other fluid-side diaphragm plate (105) from the diaphragm shaft.
5. Remove the screws (106), remove the left (114) and right (113) air covers, and remove all old gasket (12) material from the ends of the center housing (11) and the surfaces of the air covers.
6. Remove the diaphragm shaft u-cups (16) and pilot pin o-rings (1).
7. Inspect all parts for wear or damage, and replace as necessary.

Reassembly

1. Insert a diaphragm shaft u-cup (16) and a pilot pin o-ring (1) into the bores of the center housing (11).

NOTE: Make sure the lips of the u-cup face **out** of the center housing.

2. Line up the holes in the gasket (12) with the holes in the end of the center housing (11), and use six screws (106) to fasten an air cover (113 or 114) to the end of the center housing (11). Torque the screws to 35 to 45 in-lb (4.0 to 5.1 N.m).
3. Position the exhaust cover (13) and o-ring (4) on the center housing (11).
4. Repeat steps 1 and 2 for the other end of the center housing and the remaining air cover.
5. Apply medium-strength (blue) Loctite or equivalent to the threads of the fluid-side diaphragm plates (105). Install on one end of the diaphragm shaft (15) the following parts (see proper order in Fig. 9): air-side diaphragm plate (6) diaphragm (401), and fluid-side diaphragm plate (105).
NOTE: The words "AIR SIDE" on the diaphragm (401) and the flat side of the air-side diaphragm plate (6) must face toward the diaphragm shaft (15).
6. Put grease on the diaphragm shaft (15), and carefully (do not damage the shaft u-cups) run the diaphragm shaft (15) through the center housing (11) bore.
7. Repeat step 5 for the other end of the diaphragm shaft (15), and torque the fluid-side diaphragm plates (105) to 80 to 90 in-lb (9 to 10 N.m) at 100 rpm maximum.
8. Install the muffler (3).
9. Make sure all the check valve parts are in place. See Fig. 7 on page 15.
10. Reinstall the fluid covers (101) and manifolds (102 and 103), and torque the fluid cover and manifold nuts (109) to 80 to 90 in-lb (9 to 10 N.m).

Service

Diaphragms (VERDERAIR VA 15)

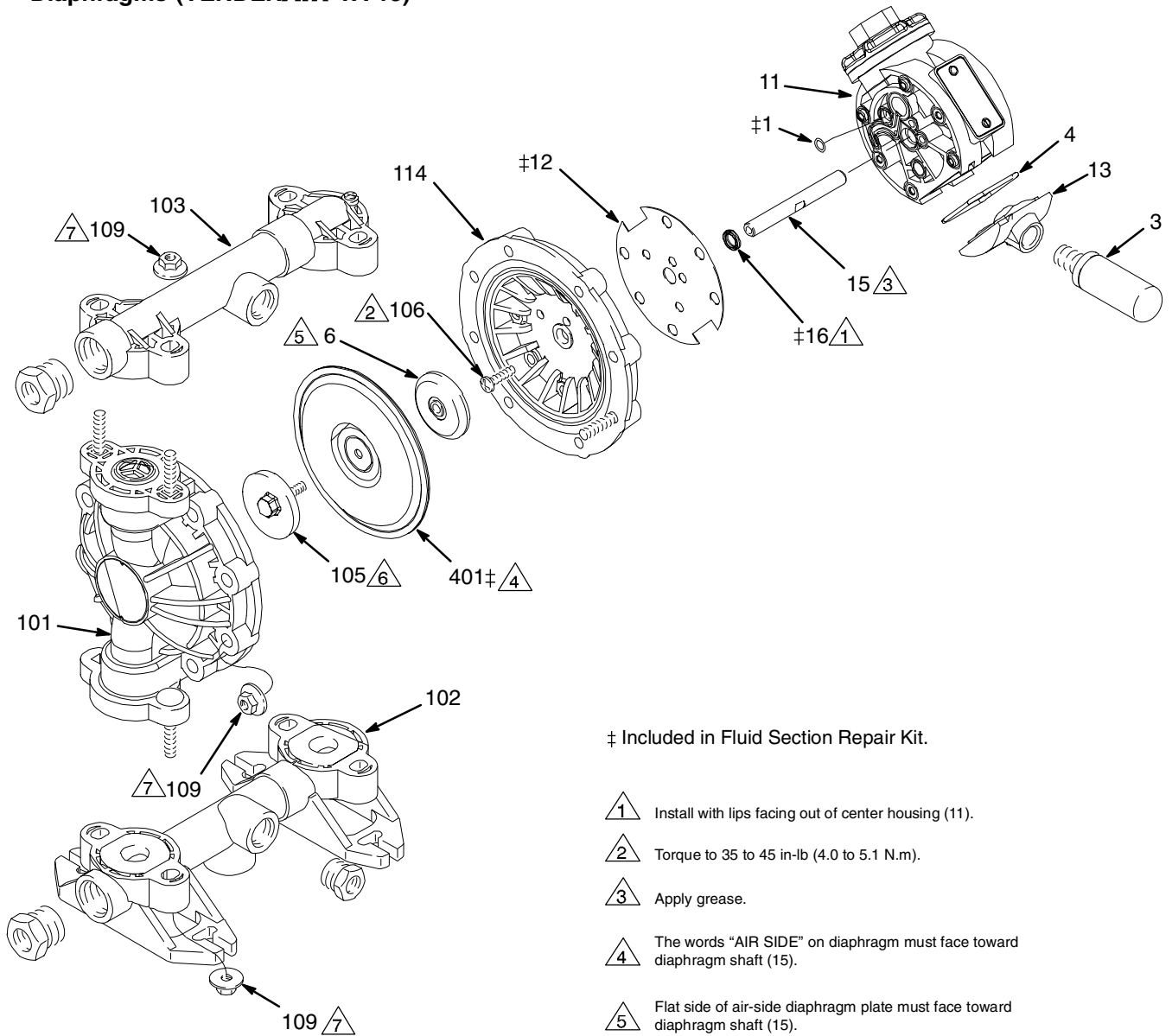

‡ Included in Fluid Section Repair Kit.

- 1 Install with lips facing out of center housing (11).
- 2 Torque to 35 to 45 in-lb (4.0 to 5.1 N.m).
- 3 Apply grease.
- 4 The words "AIR SIDE" on diaphragm must face toward diaphragm shaft (15).
- 5 Flat side of air-side diaphragm plate must face toward diaphragm shaft (15).
- 6 Apply medium-strength (blue) Loctite® or equivalent to threads, and torque to 80 to 90 in-lb (9 to 10 N.m) at 100 rpm maximum.
- 7 Torque to 80 to 90 in-lb (9 to 10 N.m).

Fig. 9

9066A

Service

Diaphragms (VERDERAIR VA 20)

NOTE: Fluid Section Repair Kit is available. See page 22 to order the correct kit for your pump. Parts included in the kit are marked with a double dagger (‡) in Fig. 10 and in the Parts Drawings and Lists. General purpose grease 819.0184 and Adhesive 819.9741 are supplied in the kit. Service the diaphragms as follows. See Fig. 10.

Disassembly



1. **Relieve the pressure.** See **Pressure Relief Procedure** on page 10.
2. Remove the manifolds (102) and fluid covers (101).
NOTE: Make sure all the check valve parts stay in place. See Fig. 8 on page 15.
3. Remove the grounding strip from the vee clamps (109), and remove the vee clamps.
4. Remove one of the fluid-side diaphragm plates (133) (whichever one comes loose first when you use a wrench on the hex of each), and pull the diaphragm shaft out of the center housing (11).
5. Use a wrench on the flats of the diaphragm shaft (15) to remove the other fluid-side diaphragm plate (133) from the diaphragm shaft.
6. Remove the screws (141) and air covers (136), and remove all old gasket (12) material from the ends of the center housing (11) and the surfaces of the air covers.
7. Remove the diaphragm shaft u-cups (16) and pilot pin o-rings (1).
8. Inspect all parts for wear or damage, and replace as necessary.

Reassembly

1. Insert a diaphragm shaft u-cup (16) and a pilot pin o-ring (1) into the end of the diaphragm shaft bore of the center housing (11).
NOTE: Make sure the lips of the u-cup face **out** of the center housing.
2. Line up the holes in the gasket (12) with the holes in the end of the center housing (11), and use six screws (141) to fasten an air cover (136) to the end of the center housing (11). Torque the screws to 35 to 45 in-lb (4.0 to 5.1 N.m).

3. Position the exhaust cover (13) and o-ring (4) on the center housing (11).
4. Repeat steps 1 and 2 for the other end of the center housing and the remaining air cover.
5. Apply medium-strength (blue) Loctite or equivalent to the threads of the screws (140). Install on one end of the diaphragm shaft (15) the following parts (see proper order in Fig. 10): air-side diaphragm plate (6), diaphragm (401), fluid-side diaphragm plate (133), o-ring (115), and screw (140).
NOTE: The words "AIR SIDE" on the diaphragm (401) and the flat side of the air-side diaphragm plate (6) must face toward the diaphragm shaft (15).
6. Put grease on the diaphragm shaft (15), and carefully (do not damage the shaft u-cups) run the diaphragm shaft (15) through the center housing (11) bore.
7. Repeat step 5 for the other end of the diaphragm shaft (15), and torque the diaphragm shaft screws (140) to 80 to 90 in-lb (9 to 10 N.m) at 100 rpm maximum.
8. Install the muffler (3).

When you install the vee clamps in step 9, orient the center housing (11) so the air inlet is approximately 45° above horizontal and the muffler (3) is approximately horizontal.

9. Apply thin film of grease to inside of vee clamps (109).
10. Position the fluid covers (101), install the vee clamps (109) around the fluid and air covers, install the grounding strip on the vee clamps, and torque the vee clamp nuts to 80 to 90 in-lb (9 to 10 N.m).
11. Make sure all the check valve parts are in place. See Fig. 8 on page 15.
12. Install the manifolds (102), and torque the manifold bolts (105) to 80 to 90 in-lb (9 to 10 N.m).

Service

Diaphragms (VERDERAIR VA 20)

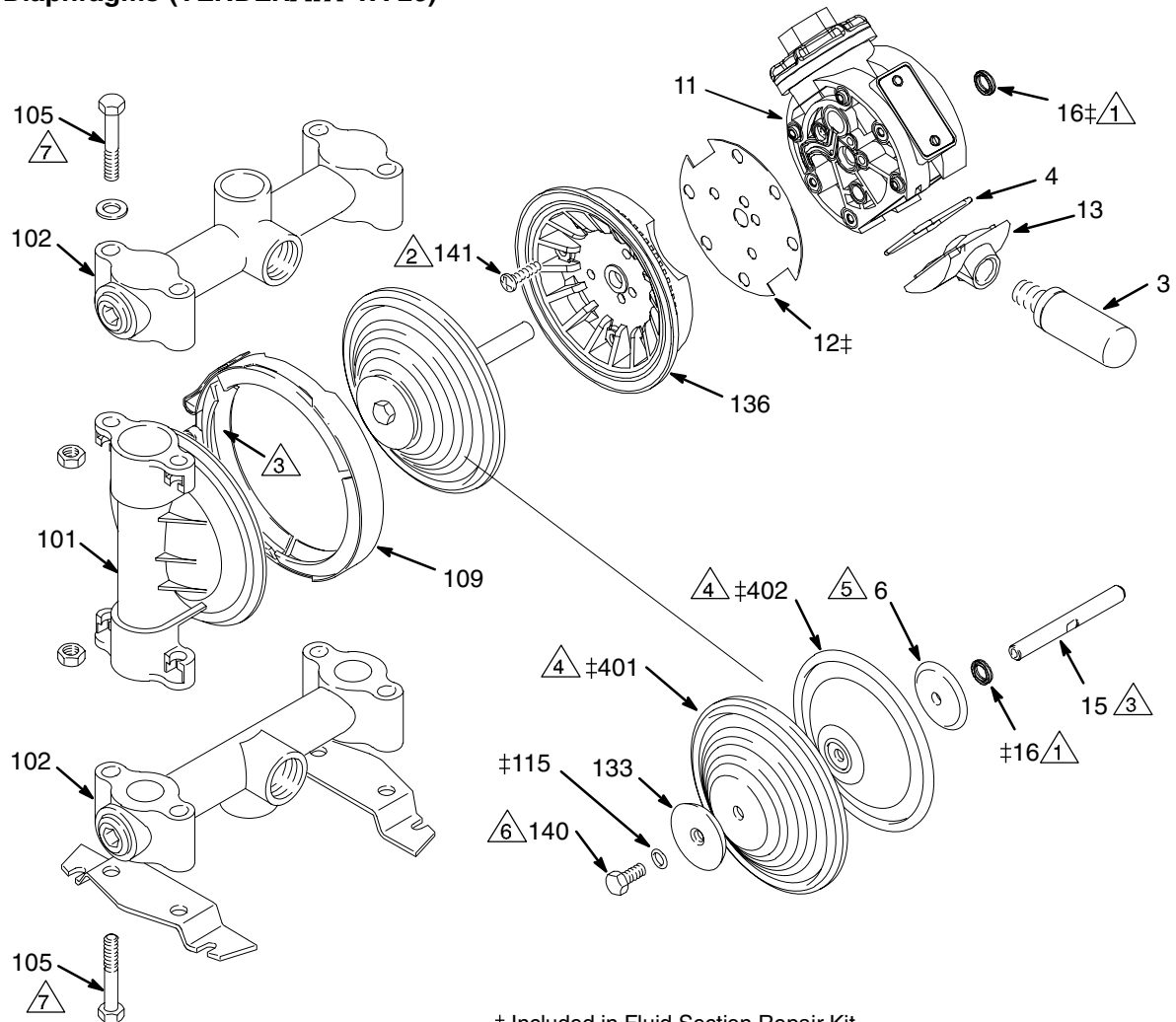

‡ Included in Fluid Section Repair Kit.

- 1 Install with lips facing out of center housing (11).
- 2 Torque to 35 to 45 in-lb (4.0 to 5.1 N.m).
- 3 Apply grease.
- 4 The words "AIR SIDE" on diaphragm and backup diaphragm must face toward diaphragm shaft (15).
- 5 Flat side of the air-side diaphragm plate must face toward diaphragm shaft (15).
- 6 Apply medium-strength (blue) Loctite® or equivalent to threads, and torque to 80 to 90 in-lb (9 to 10 N.m) at 100 rpm maximum.
- 7 Torque to 80 to 90 in-lb (9 to 10 N.m).

Fig. 10

9072A

VERDERAIR VA 15 Pump Listing

Your Model No. is marked on the pump's serial plate. See the listing of existing VERDERAIR VA 15 pumps below:

VA 15 Standard Air Valve

Ref. No.	Fluid Section	Seats and Guides	Checks	Diaphragms
810.6771	AC	AC	TF	TF
810.6758	AC	AC	SS	TF
810.6759	AC	AC	HY	HY
810.6760	AC	AC	SP	SP
810.6761	AC	AC	BN	HY
810.6762	AC	AC	BN	BN
810.6763	AC	SS	TF	TF
810.6764	AC	SS	SS	TF
810.6765	AC	PP	TF	TF
810.6766	AC	PP	BN	BN
810.6767	PP	AC	TF	TF
810.6768	PP	AC	BN	BN
810.6769	PP	SS	TF	TF
810.6770	PP	SS	SS	TF
810.6783	PP	SS	SS	SP
810.6772	PP	PP	TF	TF
810.6773	PP	PP	TF	HY
810.6774	PP	PP	TF	SP
810.6775	PP	PP	TF	VT
810.6776	PP	PP	SS	TF
810.6777	PP	PP	SS	BN
810.6778	PP	PP	HY	HY
810.6779	PP	PP	SP	TF
810.6780	PP	PP	SP	SP
810.6781	PP	PP	BN	BN
810.6782	PP	PP	VT	VT
810.6784	KY	KY	TF	TF
810.6785	KY	KY	VT	VT
819.0181*	PP	PP	SP	SP

VA 15 for Solenoid Operation

Ref. No.	Fluid Section	Seats and Guides	Checks	Diaphragms
810.6882	AC	AC	TF	TF
810.6881	AC	AC	SS	TF
810.6883	AC	AC	HY	HY
810.6884	AC	AC	SP	SP
810.6885	AC	AC	BN	HY
810.6886	AC	AC	BN	BN
810.6887	AC	SS	TF	TF
810.6888	AC	SS	SS	TF
810.6889	AC	PP	TF	TF
810.6890	AC	PP	BN	BN
810.6891	PP	AC	TF	TF
810.6892	PP	AC	BN	BN
810.6893	PP	SS	TF	TF
810.6894	PP	SS	SS	TF
810.6896	PP	PP	TF	TF
810.6897	PP	PP	TF	HY
810.6898	PP	PP	TF	SP
810.6899	PP	PP	TF	VT
810.6900	PP	PP	SS	TF
810.6901	PP	PP	SS	BN
810.6902	PP	PP	HY	HY
810.6903	PP	PP	SP	TF
810.6904	PP	PP	SP	SP
810.6905	PP	PP	BN	BN
810.6906	PP	PP	VT	VT
810.6907	PP	SS	SS	SP
810.6908	KY	KY	TF	TF
810.6909	KY	KY	VT	VT

AL = Aluminium AC = Acetal BN = Buna-N HY = Hytrel PP = Polypropylene SP = Santoprene SS = Stainless Steel
TF = PTFE VT = Viton

* 819.0181 is a Split Manifold Pump

VERDERAIR VA 20 Pump Listing

Your Model No. is marked on the pump's serial plate. See the listing of existing VERDERAIR VA 20 pumps below:

VA 20 Standard Air Valve

Ref. No.	Fluid Section	Seats and Guides	Checks	Diaphragms
810.6815	AL	AC	TF	TF
810.6816	AL	AC	TF	HY
810.6817	AL	AC	SS	TF
810.6818	AL	AC	HY	HY
810.6819	AL	AC	SP	SP
810.6820	AL	AC	BN	BN
810.6821	AL	AC	VT	VT
810.6822	AL	SS	TF	TF
810.6823	AL	SS	TF	HY
810.6824	AL	SS	SS	TF
810.6825	AL	SS	SS	HY
810.6826	AL	SS	SS	SP
810.6827	AL	SS	SS	BN
810.6828	AL	SS	SS	VT
810.6829	AL	SS	HY	HY
810.6830	AL	SS	SP	SP
810.6831	AL	SS	BN	BN
810.6832	AL	SS	VT	VT
810.6833	AL	PP	TF	TF
810.6834	AL	PP	HY	HY
810.6835	AL	PP	SP	SP
810.6836	AL	PP	BN	BN
810.6837	SS	AC	TF	TF
810.6838	SS	AC	SS	TF
810.6839	SS	SS	TF	TF
810.6840	SS	SS	SS	TF
810.6841	SS	SS	SS	HY
810.6842	SS	SS	SS	SP
810.6843	SS	SS	BN	BN
810.6844	SS	SS	VT	TF
810.6845	SS	SS	VT	VT
810.6846	SS	PP	TF	TF
810.6847	AL	AC	SS	BN

VA 20 for Solenoid Operation

Ref. No.	Fluid Section	Seats and Guides	Checks	Diaphragms
810.6939	AL	AC	TF	TF
810.6940	AL	AC	TF	HY
810.6941	AL	AC	SS	TF
810.6942	AL	AC	HY	HY
810.6943	AL	AC	SP	SP
810.6944	AL	AC	BN	BN
810.6945	AL	AC	VT	VT
810.6946	AL	SS	TF	TF
810.6947	AL	SS	TF	HY
810.6948	AL	SS	SS	TF
810.6949	AL	SS	SS	HY
810.6950	AL	SS	SS	SP
810.6951	AL	SS	SS	BN
810.6952	AL	SS	SS	VT
810.6953	AL	SS	HY	HY
810.6954	AL	SS	SP	SP
810.6955	AL	SS	BN	BN
810.6956	AL	SS	VT	VT
810.6957	AL	PP	TF	TF
810.6958	AL	PP	HY	HY
810.6959	AL	PP	SP	SP
810.6960	AL	PP	BN	BN
810.6961	SS	AC	TF	TF
810.6962	SS	AC	SS	TF
810.6963	SS	SS	TF	TF
810.6964	SS	SS	SS	TF
810.6965	SS	SS	SS	HY
810.6966	SS	SS	SS	SP
810.6967	SS	SS	BN	BN
810.6968	SS	SS	VT	TF
810.6969	SS	SS	VT	VT
810.6970	SS	PP	TF	TF
810.6971	AL	AC	SS	BN

AL = Aluminium AC = Acetal BN = Buna-N HY = Hytrel PP = Polypropylene SP = Santoprene SS = Stainless Steel
TF = PTFE VT = Viton

VERDERAIR VA 15 and VERDERAIR VA 20 Repair Kits

NOTE: Order Repair Kits separately.

To order the Air Valve Repair Kit, order **Part No. 819.6898.**

Ref. No.	Seats and Guides	Checks	Diaphragms
819.5183	PP	VT	VT
819.5176	PP	BN	BN
819.5172	PP	BN	—
819.5169	PP	SP	SP
819.5162	PP	HY	HY
819.5149	PP	TF	TF
819.5148	PP	TF	—
819.5135	SS	VT	VT
819.5130	SS	VT	—
819.5128	SS	BN	BN
819.5124	SS	BN	—
819.5107	SS	SS	TF
819.5101	SS	TF	TF
819.5100	SS	TF	—
819.5080	AC	BN	BN
819.5076	AC	BN	—
819.5066	AC	HY	HY
819.5059	AC	SS	TF
819.5054	AC	TF	HY
8195053	AC	TF	TF
819.5052	AC	TF	—
819.5010	SS	Checks	
819.5003	VT	Diaphragms	
819.5002	BN	Diaphragms	
819.5001	SP	Diaphragms	
819.4999	TF	Diaphragms	
819.5121	SS	SP	SP

AL = Aluminium AC = Acetal BN = Buna-N HY = Hytrel PP = Polypropylene SP = Santoprene SS = Stainless Steel
TF = PTFE VT = Viton

VERDERAIR VA 15 and VERDERAIR VA 20 Common Parts

Air Motor Parts List

Ref. No.	Part No.	Description	Qty
1†	819.6909	PACKING, o-ring	2
2†	819.6910	PACKING, u-cup	2
3	819.6351	MUFFLER	1
4†	819.6584	PACKING, o-ring	2
6	819.6911	PLATE, diaphragm, air side	2
7†	819.6912	PLUNGER, carriage	2
8†	819.6913	CARRIAGE	2
9†	819.6914	PIN, carriage	2
10	819.6915	COVER, valve chamber	1
11	819.6916	HOUSING, center	1
11*	819.9744	HOUSING, center	1
12†	819.6917	GASKET	2
13	819.6918	COVER, exhaust	1
14†	819.6919	PLATE, valve	1
15	819.6920	SHAFT, diaphragm	1
16*	819.7068	CONNECTOR, male	2
17*	819.9746	PIN	2

* These parts are unique to the remote piloted air motor.

Guide Parts List

Ref. No.	Part No.	Description	Qty
201†	819.4440	GUIDE; acetal	4
202†	819.4441	STOP; acetal	4
201†	819.4442	GUIDE; sst	4
202†	819.4443	STOP; sst	4
201†	819.4444	GUIDE; polypropylene	4
202†	819.4445	STOP; polypropylene	4
201†	819.6925	GUIDE; Kynar®	4
202†	819.6926	STOP; Kynar®	4
201†	819.6927	SPACER	4
202†	819.6928	VALVE, duckbill	4

Ball Parts List

Digit	Ref. No.	Part No.	Description	Qty
1	301†	819.4446	BALL; PTFE	4
3	301†	819.4447	BALL; sst	4
5	301†	819.4448	BALL; Hytrel®	4
6	301†	819.4449	BALL; Santoprene®	4
7	301†	819.4450	BALL; buna-N	4
8	301†	819.4415	BALL; Viton®	4

Diaphragm Parts List

Diaphragm Material	Ref. No.	Part No.	Description	Qty
P T F E	16†	819.6910	PACKING, u-cup	2
	401†	819.4453	DIAPHRAGM; PTFE	2
	402†	819.4452	DIAPHRAGM, back-up; polyurethane	2
H Y T R E L	16†	819.6910	PACKING, u-cup	2
	401†	819.4454	DIAPHRAGM; Hytrel®	2
S A N T O P R E N E	16†	819.6910	PACKING, u-cup	2
	401†	819.4414	DIAPHRAGM; Santoprene®	2
B U N A - N	16†	819.6910	PACKING, u-cup	2
	401†	819.4455	DIAPHRAGM; buna-N	2
V I T O N	16†	819.6910	PACKING, u-cup	2
	401†	819.4416	DIAPHRAGM; Viton®	2

† Included in Air Valve Repair Kit 819.6898.

‡ Included in Fluid Section Repair Kit.

VERDERAIR VA 15 Parts Drawing

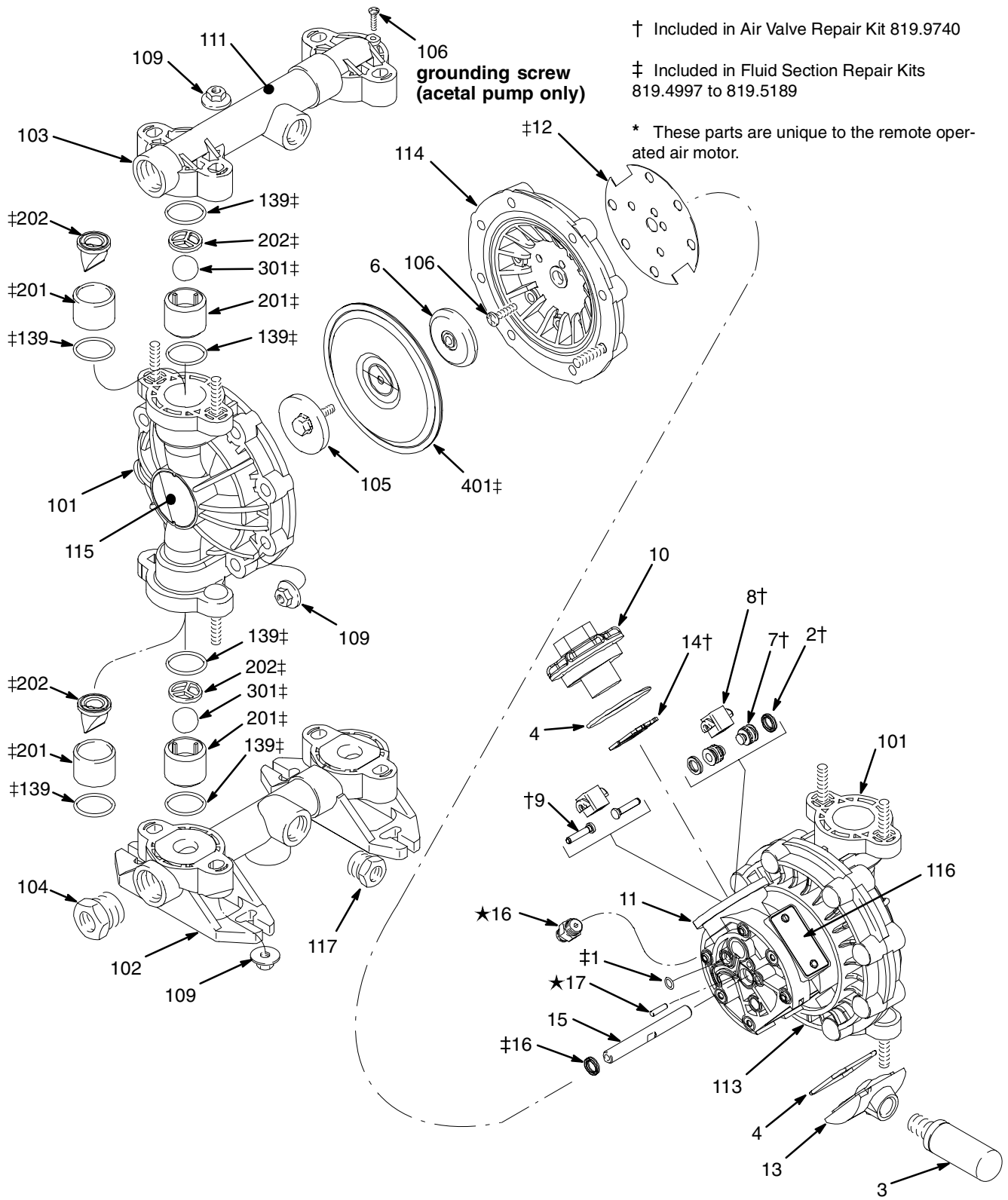

9064A

VERDERAIR VA 15 Fluid Section Parts List

See page 23 for Air Motor Parts List

VERDERAIR VA 15 Fluid Section Parts List

Ref. No.	Acetal Pumps			Polypropylene Pumps			Kynar® Pumps		
	Part No.	Description	Qty	Part No.	Description	Qty	Part No.	Description	Qty
101	819.6929	COVER, fluid; acetal	2	819.6945	COVER, fluid; polypropylene	2	819.6954	COVER, fluid; Kynar®	2
102	819.6931	MANIFOLD, inlet; acetal; BSPT	1	819.6947	MANIFOLD, inlet; polypropylene;BSPT	1	819.6956	MANIFOLD, inlet; Kynar®; BSPT	1
				819.0054	MANIFOLD, split, inlet; polypropylene; BSPT (For 819.0181 only)	2			
103	819.6933	MANIFOLD, outlet; acetal; BSPT	1	819.6949	MANIFOLD, outlet; polypropylene;BSPT	1	819.6958	MANIFOLD, outlet; Kynar®; BSPT	1
				819.0053	MANIFOLD, split, outlet;polypropylene; BSPT (For 819.0181 only)	2			
104	819.6935	PLUG; acetal; 3/4 BSPT	2	819.6951	PLUG; polypropylene; 3/4 BSPT	2	819.6960	PLUG; Kynar®; 3/4 BSPT	2
105	819.0190	PLATE, diaphragm, fluid; acetal	2	819.0202	PLATE, diaphragm, fluid; polypropylene	2	819.6961	PLATE, diaphragm, fluid; Kynar®	2
106	819.6936	SCREW, mach.	13	819.6936	SCREW, mach.	12	819.6936	SCREW, mach.	12
109	819.6937	NUT, hex, large flng	24	819.6937	NUT, hex, large flng	24	819.6937	NUT, hex, large flng	24
111	819.0195	LABEL, warning	1	819.0195	LABEL, warning	1	819.0195	LABEL, warning	1
113	819.6938	COVER, air, right	1	819.6938	COVER, air, right	1	819.6938	COVER, air, right	1
114	819.6939	COVER, air, left	1	819.6939	COVER, air, left	1	819.6939	COVER, air, left	1
115	819.6940	LABEL, identification	2	819.6940	LABEL, identification	2	819.6940	LABEL, identification	2
116	819.5968	PLATE, designation	1	819.5968	PLATE, designation	1	819.5968	PLATE, designation	1
117	819.6942	PLUG, acetal; 1/2 BSPT	2	819.6953	PLUG; polypropylene; 1/2 BSPT	2	819.6963	PLUG; Kynar®; 1/2 BSPT	2
119	819.6943	RIVET (for plate 116)	2	819.6943	RIVET (for plate 116)	2	819.6943	RIVET (for plate 116)	2
139 ‡	819.6944	PACKING, o-ring; encapsulated	8	819.6944	PACKING, o-ring; encapsulated	8	819.6944	PACKING, o-ring; encapsulated	8

VERDERAIR VA 20 Parts Drawing

† Included in Air Valve Repair Kit 819.9740

‡ Included in Fluid Section Repair Kits 819.4997 to 819.5189

* These parts are unique to the remote operated air motor.

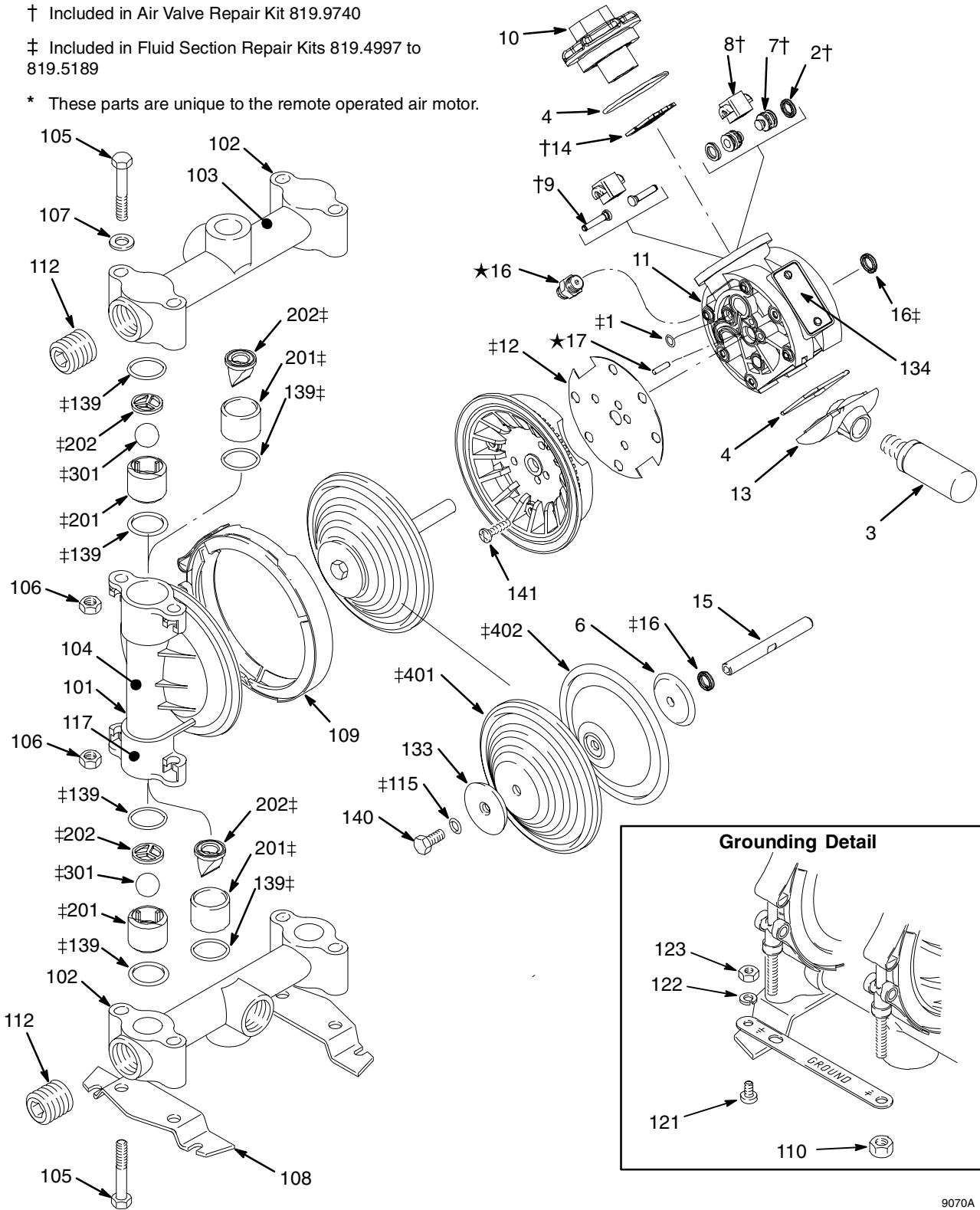

9070A

VERDERAIR VA 20 Fluid Section Parts List

See page 23 for Air Motor Parts List

VERDERAIR VA 20 Fluid Section Parts List

Ref. No.	Aluminum Pumps			Stainless Steel (sst) Pumps		
	Part No.	Description	Qty	Part No.	Description	Qty
101	819.4457	COVER, fluid; aluminum	2	819.4467	COVER, fluid; sst	2
102	819.6964	MANIFOLD; aluminum; BSPT	2	819.6970	MANIFOLD; sst; BSPT	2
103	819.4434	LABEL, warning	1	819.4434	LABEL, warning	1
104	819.6965	LABEL, identification	1	819.6965	LABEL, identification	1
105	819.4459	SCREW; 3/8-16; 2.25 in. (57.2 mm)	8	819.4459	SCREW; 3/8-16; 2.25 in. (57.2 mm)	8
106	819.4460	NUT, hex; 3/8-16; sst	8	819.4460	NUT, hex; 3/8-16; sst	8
107	819.4461	WASHER, flat; 3/8 in.; sst	4	819.4461	WASHER, flat; 3/8 in.; sst	4
108	819.4462	BASE, feet	2	819.4462	BASE, feet	2
109	819.4433	CLAMP, vee	2	819.4433	CLAMP, vee	2
110	819.0198	NUT, clamp; 1/4-28	2	819.0198	NUT, clamp; 1/4-28	2
111	819.6354	STRIP, grounding	1	819.6354	STRIP, grounding	1
112	819.6967	PLUG, steel; BSPT	2	819.6971	PLUG; sst; BSPT	2
115‡	819.6557	O-RING; PTFE	2	819.6557	O-RING; PTFE	2
117	819.4466	LABEL, warning	1			
121	819.6880	SCREW; 10-24; 0.31 in. (8 mm)	1	819.6880	SCREW; 10-24; 0.31 in. (8 mm)	1
122	819.0187	LOCKWASHER; #10	1	819.0187	LOCKWASHER; #10	1
123	819.0185	NUT, hex; 10-24	1	819.0185	NUT, hex; 10-24	1
133	819.6968	PLATE, diaphragm, fluid side; sst	2	819.6968	PLATE, diaphragm, fluid side; sst	2
134	819.5968	PLATE, designation	1	819.5968	PLATE, designation	1
136	819.6969	COVER air	2	819.6969	COVER air	2
139‡	819.4432	O-RING; PTFE	8	819.4432	O-RING; PTFE	8
140	819.6556	SCREW, flange; hex head	2	819.6556	SCREW, flange; hex head	2
141	819.6936	SCREW, machine	12	819.6936	SCREW, machine	12
142	819.6943	RIVET (for plate 134)	2	819.6943	RIVET (for plate 134)	2

‡ Included in Fluid Section Repair Kit.

VERDERAIR VA 15 Technical Data

Maximum fluid working pressure	100 psi; 0.7 MPa (7 bar)
Air pressure operating range	30 to 100 psi; 0.18 to 0.7 MPa (1.8 to 7 bar)
Maximum air consumption	28 scfm; 0.793 cubic meters/min.
Maximum free flow delivery	15 gpm; 57 l/min
Maximum pump speed	400 cpm
Liters per cycle	0.15
Maximum suction lift (water)	15 ft; 4.5 m dry, 25 ft; 7.6 m wet
Maximum size pumpable solids	3/32 in.; 2.5 mm
Sound power level (measured per ISO standard 9614-2)	
At 70 psig; 0.48 MPa (4.8 bar) at 50 cycles per minute	77 dBa
At 100 psig; 0.7 MPa (7 bar) at maximum cycles per minute	95 dBa
Sound pressure level (measured 1 meter from pump)	
At 70 psig; 0.48 MPa (4.8 bar) at 50 cycles per minute	67 dBa
At 100 psig; 0.7 MPa (7 bar) at maximum cycles per minute	85 dBa
Air inlet size	1/4 npt(f)
Air exhaust port size	3/8 npt(f)
Fluid inlet size.	1/2 and 3/4 in. bspt(f)
Fluid outlet size.	1/2 and 3/4 in. bspt(f)
Wetted parts (in addition to ball, seat, and diaphragm materials, which vary by pump)	
Polypropylene pumps	polypropylene, PTFE
Acetal pumps	groundable acetal, PTFE
Kynar® pumps	Kynar, PTFE
Non-wetted external parts	polypropylene, stainless steel, polyester and aluminum (labels), nickel-plated brass
Weight (approximate)	
Polypropylene pumps	6.5 lb; 2.9 kg
Acetal pumps	7.8 lb; 3.5 kg
Kynar® pumps	8.5 lb; 3.9 kg

Kynar® is a registered trademark of Atochem North America, Incorporated.

Hytrel®, and Viton®, are registered trademarks of the DuPont Company.

Santoprene® is a registered trademark of the Monsanto Company.

Loctite® is a registered trademark of the Loctite Corporation.

VERDERAIR VA 15 Dimensions

FRONT VIEW

* Pumps with duckbill check valves are shipped with the inlet manifold on top and the outlet manifold on the bottom. To make the inlet manifold on the bottom and the outlet manifold on the top, rotate each of the four duckbill assemblies vertically 180° as shown below.

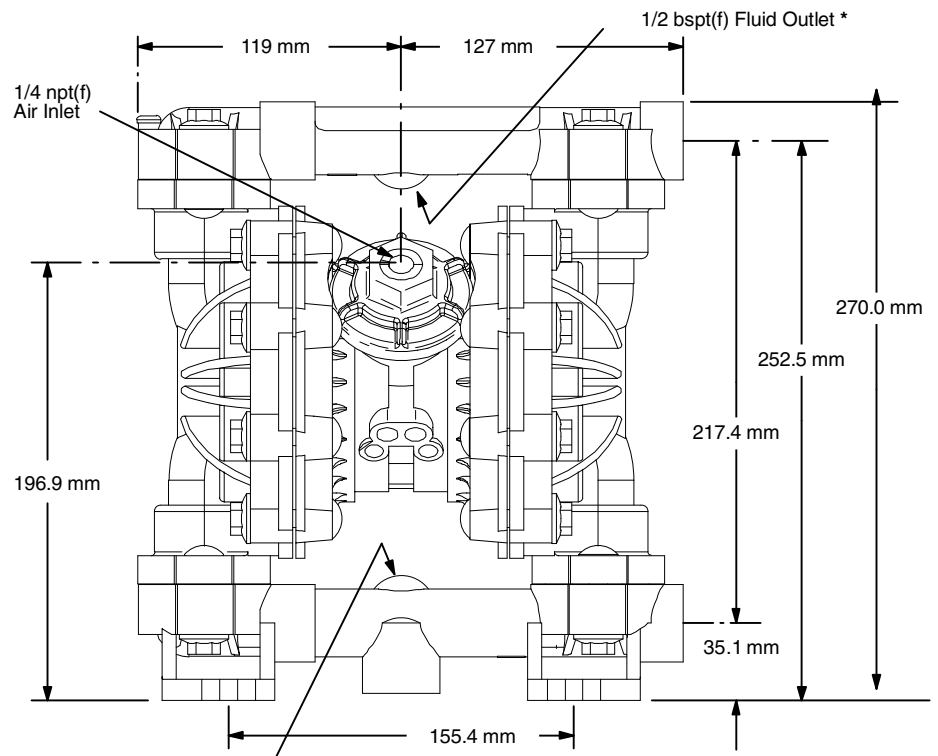
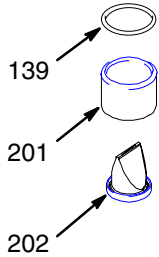

SIDE VIEW

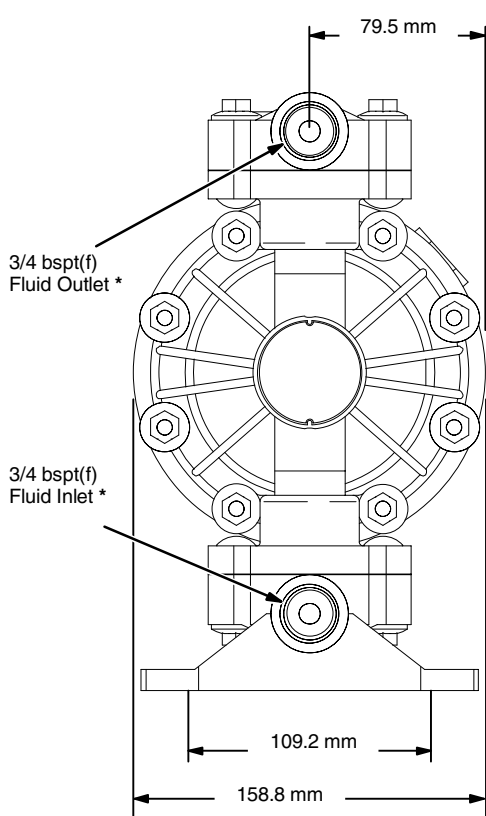

PUMP MOUNTING HOLE PATTERN

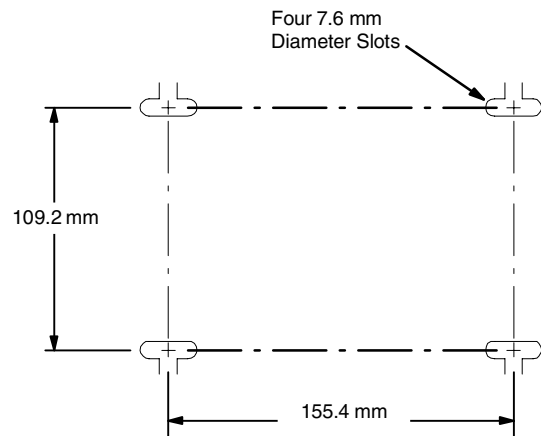

9077A

VERDERAIR VA 20 Technical Data

Maximum fluid working pressure	100 psi; 0.7 MPa (7 bar)
Air pressure operating range	30 to 100 psi; 0.18 to 0.7 MPa (1.8 to 7 bar)
Maximum air consumption	28 scfm; 0.793 cubic meters/min.
Maximum free flow delivery	16 gpm; 61 l/min
Maximum pump speed	400 cpm
Liters per cycle	0.15
Maximum suction lift (water)	15 ft; 4.5 m dry, 25 ft; 7.6 m wet
Maximum size pumpable solids	3.32 in.; 2.5 mm
Sound power level (measured per ISO standard 9614-2)	
At 70 psig; 0.48 MPa (4.8 bar) at 50 cycles per minute	77 dBa
At 100 psig; 0.7 MPa (7 bar) at maximum cycles per minute	95 dBa
Sound pressure level (measured 1 meter from pump)	
At 70 psig; 0.48 MPa (4.8 bar) bar at 50 cycles per minute	67 dBa
At 100 psig; 0.7 MPa (7 bar) at maximum cycles per minute	85 dBa
Air inlet size	1/4 npt(f)
Air exhaust port size	3/8 npt(f)
Fluid inlet size.	3/4 bspt(f)
Fluid outlet size.	3/4 bspt(f)
Wetted parts (in addition to ball, seat, and diaphragm materials, which vary by pump)	
Aluminum pumps	aluminum, stainless steel, PTFE, zinc-plated steel
Stainless steel pumps	316 stainless steel, PTFE
Non-wetted external parts	polypropylene, stainless steel, polyester (labels), nickel-plated brass, epoxy-coated steel (feet)
Weight (approximate)	
Aluminum pumps	8.5 lb; 3.9 kg
Stainless steel pumps	18 lb; 8.2 kg

Kynar® is a registered trademark of Atochem North America, Incorporated.

Hytrel®, and Viton®, are registered trademarks of the DuPont Company.

Santoprene® is a registered trademark of the Monsanto Company.

Loctite® is a registered trademark of the Loctite Corporation.

VERDERAIR VA 20 Dimensions

* Pumps with duckbill check valves are shipped with the inlet manifold on top and the outlet manifold on the bottom. To make the inlet manifold on the bottom and the outlet manifold on the top, rotate each of the four duckbill assemblies vertically 180° as shown below.

FRONT VIEW

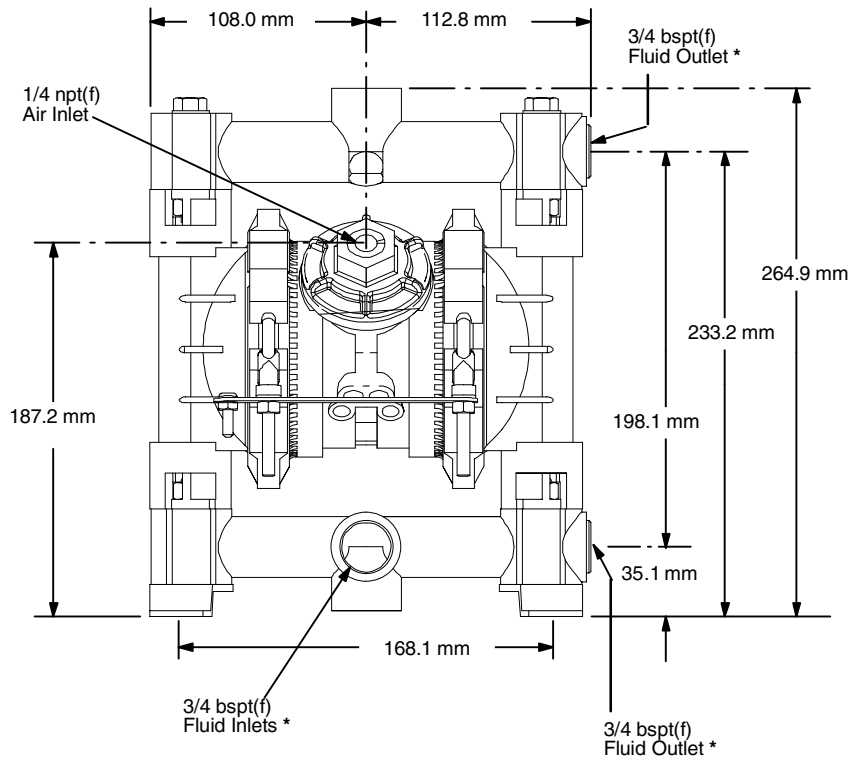

SIDE VIEW

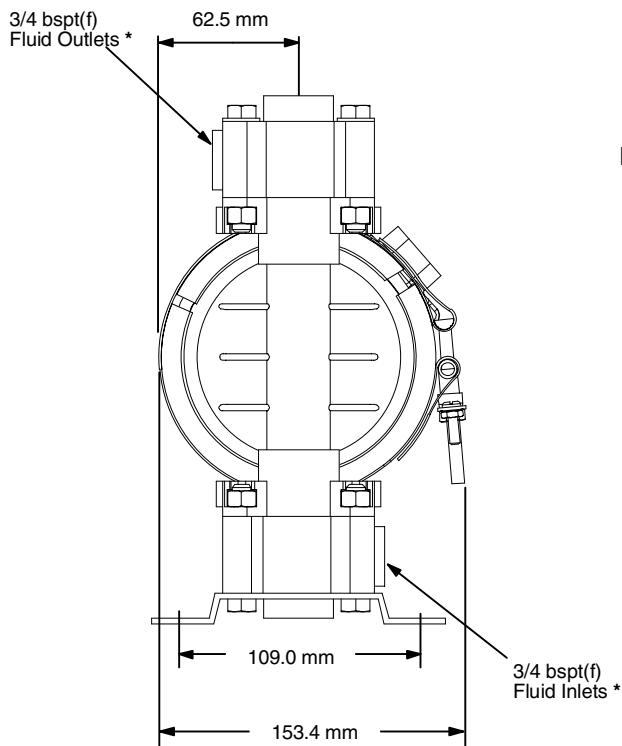

PUMP MOUNTING HOLE PATTERN

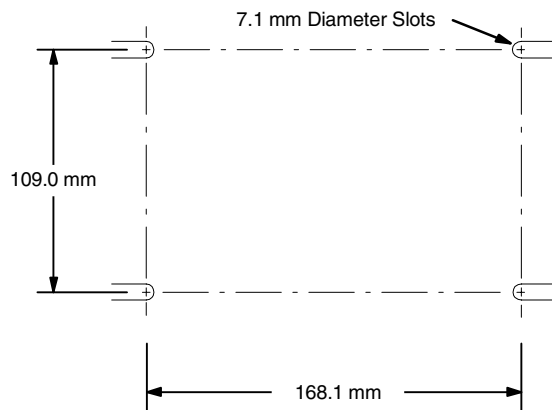

9078A

VERDERAIR VA 15 and VA 20 Performance Charts

Fluid Outlet Pressure

Test Conditions: Pump tested in water with inlet submerged.

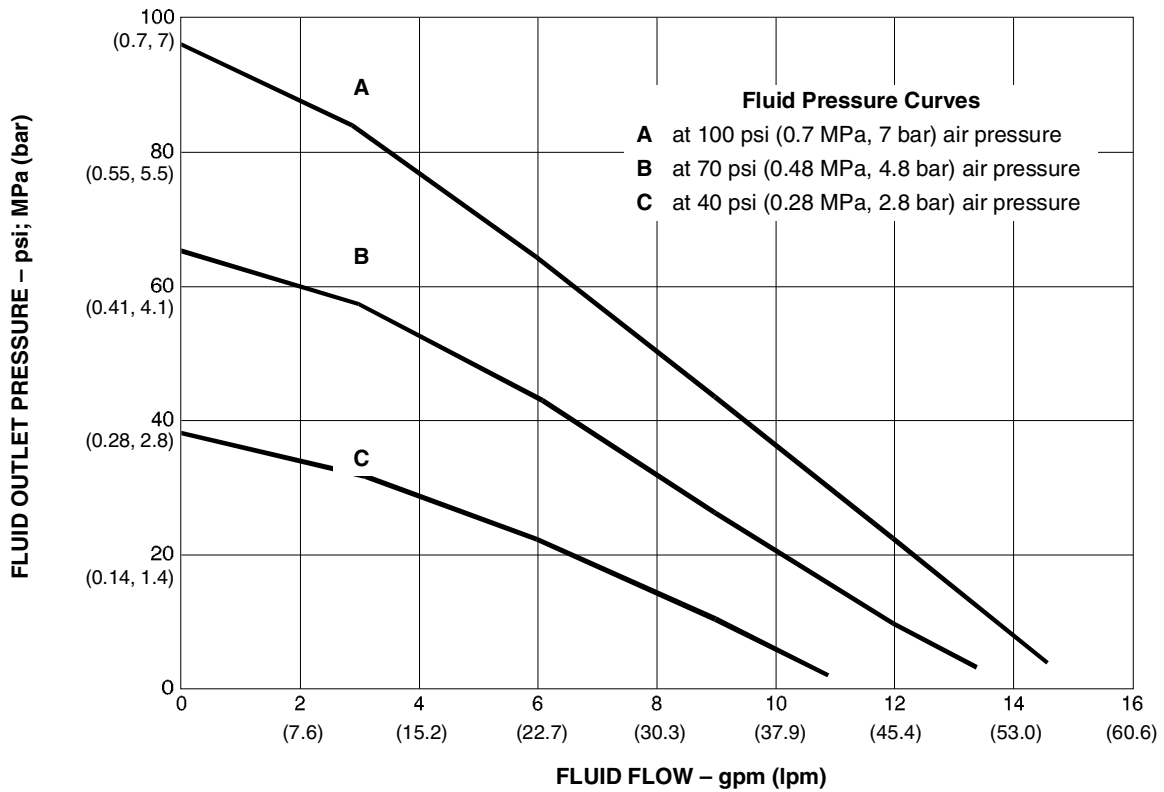

To find Fluid Outlet Pressure (psi/MPa/bar) at a specific fluid flow (gpm/lpm) and operating air pressure (psi/MPa/bar):

1. Locate fluid flow rate along bottom of chart.
2. Follow vertical line up to intersection with selected fluid outlet pressure curve.
3. Follow left to scale to read fluid outlet pressure.

VERDERAIR VA 15 and VA 20 Performance Charts

Air Consumption

Test Conditions: Pump tested in water with inlet submerged.

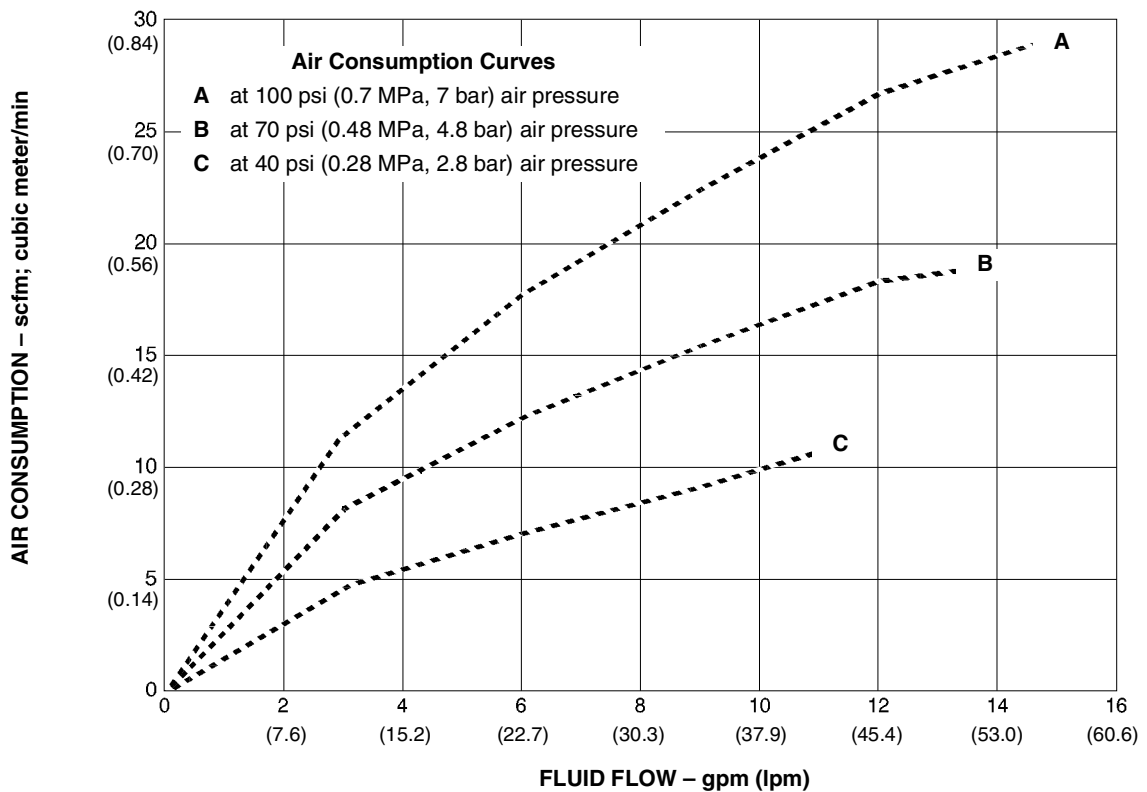

To find Pump Air Consumption (scfm or m³/min) at a specific fluid flow (gpm/lpm) and air pressure (psi/MPa/bar):

1. Locate fluid flow rate along bottom of chart.
2. Read vertical line up to intersection with selected air consumption curve.
3. Follow left to scale to read air consumption.

Customer Services/Guarantee

CUSTOMER SERVICES

If you require spare parts, please contact your local distributor, providing the following details:

- Pump Model
- Type
- Serial Number, and
- Date of First Order.

GUARANTEE

All VERDER pumps are warranted to the original user against defects in workmanship or materials under normal use (rental use excluded) for two years after purchase date. This warranty does not cover failure of parts or components due to normal wear, damage or failure which in the judgement of VERDER arises from misuse.

Parts determined by VERDER to be defective in material or workmanship will be repaired or replaced.

LIMITATION OF LIABILITY

To the extent allowable under applicable law, VERDER's liability for consequential damages is expressly disclaimed. VERDER's liability in all events is limited and shall not exceed the purchase price.

WARRANTY DISCLAIMER

VERDER has made an effort to illustrate and describe the products in the enclosed brochure accurately; however, such illustrations and descriptions are for the sole purpose of identification and do not express or imply a warranty that the products are merchantable, or fit for a particular purpose, or that the products will necessarily conform to the illustration or descriptions.

PRODUCT SUITABILITY

Many regions, states and localities have codes and regulations governing the sale, construction, installation and/or use of products for certain purposes, which may vary from those in neighbouring areas. While VERDER attempts to assure that its products comply with such codes, it cannot guarantee compliance, and cannot be responsible for how the product is installed or used. Before purchasing and using a product, please review the product application as well as the national and local codes and regulations, and be sure that product, installation, and use complies with them.



EC-DECLARATION OF CONFORMITY

EU-OVERENSSTEMMELSESERKLÆRING, EYILMOITUS YHTÄPITÄVYYDESTÄ, CE-DECLARATION DE CONFORMITE, EG-ÜBERENSTIMMUNG SERKLÄRUNG, DICHIARAZIONE DI CONFORMITÀ-CE, EG-VERKLARING VAN O VEREENSTEMMING, EC-DECLARAÇÃO DE CONFORMIDADE, EC-DECLARACIÓN DE CONFORMIDAD, EG-DECLARATION OM ÖVERENSSTÄMMELSE, ΔΗΛΩΣΗ ΣΥΜΜΟΡΦΩΣΗΣ-ΕΚ

Model

Model, Malli, Modèle, Modell, Modello, Model, Modelo, Modelo, Model, Μοντέλο

VERDERAIR VA 15 AND VA 20

Part No.

Part No., Osasto, Référence, Teile-Nr., Parte Codice, Part Nr., Peça No., Referencia, Part No., Ap. Αντάλλακτικού

810.6758 to 810.6787 - 810.6815 to 810.6847
810.0181, 810.3543 - 810.6881 to 810.6909
810.7004, 810.7008 - 810.6939 to 810.6971

This Product Complies With The Following European Community Directives:

Dette produkt opfylder kravene i de følgende direktiver af det Europæiske Fællesskab, Tämä tuote on yhtäpitävä ministeineuvoston allamainitun direktiivin vaatimusten kanssa, Ce produit se conforme aux directives de la Communauté Européenne suivantes, Dieses Produkt entspricht den nachstehend aufgeführten Richtlinien der Europäischen Union, Questo prodotto si conforma ai seguenti direttivi della Comunità europea, Dit produkt voldoet aan de volgende richtlijnen van de Europese Gemeenschap, Este Produto Cumpre As Seguintes Directivas das Comunidades Europeias, Este producto cumple con las directivas siguientes de la Comunidad Económica Europea, Denna Product Överensstämmer Med Kraven Ministerådets Direktiv Enligt Följande, Το Προϊόν Αυτό Έχει Κατασκευαστεί Σύμφωνα Με Τις Παρακάτω Κοινοτικές Οδηγές:

98/37/EC Machinery Directive

94/9/EC ATEX Directive (Ex II 2 G EEx c IIA T6)

The Following Standards Were Used To Verify Compliance With The Directives:

De følgende standarder blev anvendt som bekræftelse på at direktivernes bestemmelser overholdes, Allaolevat standardia on käyretty vahvistamaan yhtäpitävyyttä direktiivin kanssa, Les normes suivantes ont été appliquées pour vérifier que ce produit se conforme aux directives, Die folgenden Normen garantieren die Übereinstimmung mit diesen Richtlinien, Sono state usate le seguenti norme per verificare la conformità ai direttivi, De overeenstemming met de richtlijnen werd gecontroleerd aan de hand van de volgende normen, Para Verificar A Conformidade Com As Directivas Utilizaram-se As Seguintes Normas, Las normas siguientes han sido utilizadas para verificar que el producto cumpla con las directivas correspondientes, Följande standard Har Använts För Att Bestyrka Överensstämmelse Med Direktiven, Ως Κριτήρια Τήρησης Των Οδηγιών χρησιμοποιήθηκαν Τα Παρακάτω Πρότυπα:

EN 292 EN 1127-1 EN 13463-1

ISO 9614-1

EC Notified Body:

EU Bemyndigede Organer, Tiedon Antava Viranomainen, Organisme Agréé, EG Anerkanntes Organ, Ente-CE notificato, EG Aangemelde Instantie, Organismo Reconhecido pela CE, Organismo Certificado por la CE, Underrätad EG Myndighet, Επίσημο Κοινοτικό Όργανο

0359

Approved By:

Attesteret Ved, Todistaa, Approuvée Par, Genehmigt Durch, Approvato da, Goedgekeurd Door, Para Aprovação, Aprobado par, Intygas Av, Εγκρίθηκε Από

Date

Dato, Päiväys, Date, Datum, Data, Datum, Data, Jecha, Datum, Ημερομηνία

19May2004

Frank Meersman

Date

Dato, Päiväys, Date, Datum, Data, Datum, Data, Jecha, Datum, Ημερομηνία

19May2004

DIRECTOR (Print)

Verder Ltd.
Whitehouse street
Leeds LS10 1AD
Great Britain

Part No. : 819.5963

819.6900 35

Austria

VERDER Ges. mbH Austria
Perfektasstrasse 86
A-1232 Wien
Tel. 0222-8651074-0
Fax 0222-8651076

Belgium

VERDER Belgium N.V.
Industrieterrein Den Hoek
Bijkhoevelaan 3
B-2110 Wijnegem
Tel. 03-3263336
Fax 03-3263650

Czech Republic

VERDER Praha s.r.o.
Pod pekárnami 15
CZ-19000 Praha 9
Tel. 02-6603 21 17
Fax 02-6603 21 15

U.S.A

VERDER Inc
PO Box 364
Pocopson, PA
Tel. 610 793 4250
Fax 610 793 4333

Germany

VERDER Deutschland GmbH
Rheinische Straße 43
PO Box 1739
D-42781 Haan
Tel. 02129-9342-0
Fax 02129-9342-60

France

POMPES VERDER s.a.r.l.
Parc des Bellevues
Rue du Gros Chêne
F-95610 Eragny sur Oise
Tel. 01 34 64 31 11
Fax 01 34 64 44 50

The Netherlands

VERDER VLEUTEN B.V.
Utrechtseweg 4a
PO box 1
NL-3450 AA Vleuten
Tel. 030-6779230
Fax 030-6773945

Poland

VERDER Polska Sp. z o.o
ul. Kamińskiego 201-219
PL-51-124 Wrocław, Polska
Tel. 0 71726158 w.e.w. 59
Fax 0 71726474

Romania

VERDER Romania s.r.l.
Soseaua Viilor no.79
RO-Sector 5, Bucuresti
Tel. 01-335 45 92
Fax 01-337 33 92

United Kingdom

VERDER LTD.
White House Street
Leeds GB-LS10 1AD
Tel. 0113-244 61 11
Fax 0113-246 56 49