

**WARREN
RUPP®**

Quality System
ISO9001 Certified

Environmental
Management System
ISO14001 Certified

IDEX
FLUID & METERING



CE



See pages 2, 7 & 8
for ATEX ratings.

SANDPIPER®

A WARREN RUPP PUMP BRAND

**S20
Non-Metallic Ball Valve**

Design Level 3

**Air-Operated
Double Diaphragm Pump**

ENGINEERING, PERFORMANCE
& CONSTRUCTION DATA

INTAKE/DISCHARGE PIPE SIZE 2" Universal Flange (Fits ANSI & DIN Flange)	CAPACITY 0 to 160 gallons per minute (0 to 605 liters per minute)	AIR VALVE No-lube, no-stall design	SOLIDS-HANDLING Up to .66 in. (17mm)	HEADS UP TO 100 psi or 231 ft. of water (7 bar or 70 meters)	DISPLACEMENT/STROKE .46 Gallon / 1.73 liter
---	---	--	---	--	--

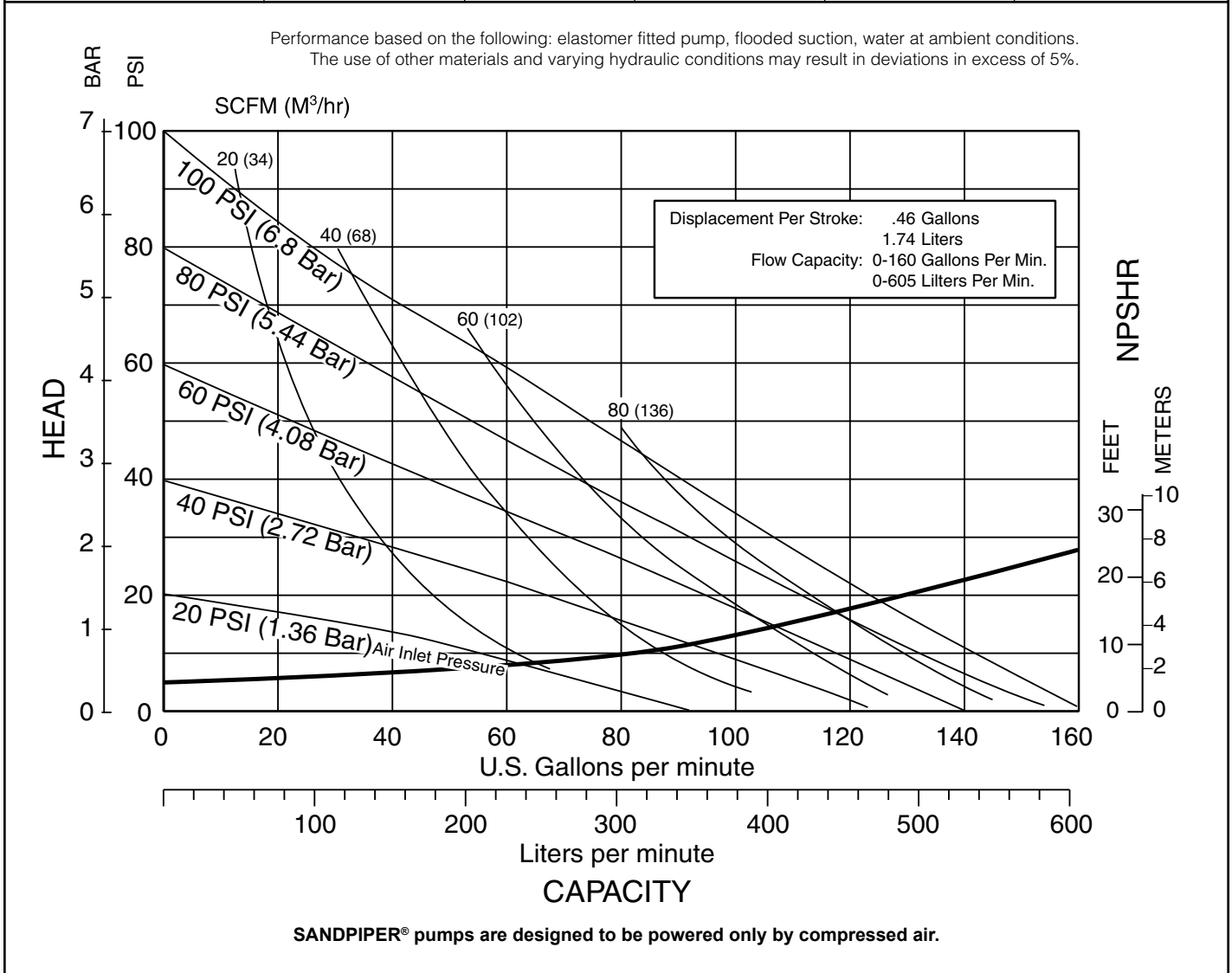

Warren Rupp, Inc. • A Unit of IDEX Corporation • 800 N. Main St., Mansfield, Ohio 44902 USA
Telephone (419) 524-8388 • Fax (419) 522-7867 • www.warrenrupp.com

Explanation of Pump Nomenclature

S20 Non-Metallic • Design Level 3 • Ball Valve

Model	Pump Brand	Pump Size	Check Valve Type	Design Level	Wetted Material	Diaphragm/Check Valve Materials	Check Valve Seat	Non-Wetted Material Options	Porting Options	Pump Style	Pump Options	Shipping Kit Options	Weight lbs. (kg)
S20B3P1PPUS000.	S	20	B	3	P	1	P	P	U	S	0	00.	90 (41)
S20B3K1KPUS000.	S	20	B	3	K	1	K	P	U	S	0	00.	125 (57)
S20B3P2PPUS000.	S	20	B	3	P	2	P	P	U	S	0	00.	95 (43)
S20B3K2KPUS000.	S	20	B	3	K	2	K	P	U	S	0	00.	130 (59)
S20B3PGPPUS000.	S	20	B	3	P	G	P	P	U	S	0	00	126 (57)
S20B3KGGKUS000.	S	20	B	3	K	G	K	P	U	S	0	00	131 (59)
S20B3C1PCUS000.	S	20	B	3	C	1	P	C	U	S	0	00.	94 (43)
S20B3C2PCUS000.	S	20	B	3	C	2	P	C	U	S	0	00.	100 (45)

Note: Models listed in the table are for reference only. See nomenclature below for other models.

Pump Brand

S= SANDPIPER®

Pump Size

20= 2"

Check Valve Type

B= Ball

Design Level

3= Design Level 3

Wetted Material

K= PVDF

P= Polypropylene

 C= Conductive Polypropylene

Diaphragm / Check Valve Materials

1= Santoprene/Santoprene

2= PTFE-Santoprene Backup/PTFE

6= PTFE Pumping, PTFE-Neoprene Backup Driver/PTFE

B= Nitrile/Nitrile

C= FKM / PTFE

G=PTFE-Neoprene Backup/PTFE

N= Neoprene/Neoprene

Z= One-Piece Bonded/PTFE

Check Valve Seat

K= PVDF

P= Polypropylene

Non-Wetted Material Options

C= Carbon Filled Conductive

Polypropylene

P= 40%Glass Filled Polypropylene

1= 40%Glass Filled Polypropylene w/PTFE Coated Hardware

Porting Options

U= Universal Flange

(Fits ANSI & DIN)

7= Dual Porting (ANSI)

8= Top Dual Porting (ANSI)

9= Bottom Dual Porting (ANSI)

Pump Style

D=with Electronic Leak Detection (110V)

E=with Electronic Leak Detection (220V)

M=with Mechanical Leak Detection

S= Standard

V= with Visual Leak Detection

Pump Options

 0= None

1= Sound Dampening Muffler

2= Mesh Muffler

3= High temperature Air Valve w/Integral Muffler

4= High temperature Air Valve w/Sound Dampening Muffler

5= High temperature Air Valve w/Mesh Muffler

 6= Metal Muffler

 7= Metal Muffler w/Grounding Cable

Kit Options

 00.=None

P0.=10-30VDC Pulse Output Kit

 P1.=Intrinsically-Safe 5-30VDC, 110/120VAC 220/240 VAC Pulse Output Kit

P2.=110/120 or 220/240VAC Pulse Output Kit

E0.=Solenoid Kit with 24VDC Coil

 E1.=Solenoid Kit with 24VDC Explosion-Proof Coil

E2.=Solenoid Kit with 24VAC/12VDC Coil

 E3.=Solenoid Kit with 12VDC Explosion-Proof Coil

E4.=Solenoid Kit with 110VAC Coil

 E5.=Solenoid Kit with 110VAC Explosion-Proof Coil

E6.=Solenoid Kit with 220VAC Coil

 E7.=Solenoid Kit with 220VAC Explosion-Proof Coil

 E8.=Solenoid Kit with 110VAC, 50 Hz Explosion-Proof Coil

 E9.= Solenoid Kit with 230VAC, 50 Hz Explosion-Proof Coil

SP.= Stroke Indicator Pins

 A1.=Solenoid Kit with 12 VDC ATEX Compliant Coil

 A2.=Solenoid Kit with 24 VDC ATEX Compliant Coil

 A3.=Solenoid Kit with 110/120 VAC 50/60 Hz ATEX Compliant Coil

 A4.=Solenoid Kit with 220/240 VAC 50/60 Hz ATEX Compliant Coil

(1)  II 1G c T5
II 3/1 G c T5
II 1D c T100°C
I M1 c
I M2 c

 Note: Pumps are only ATEX compliant when ordered with wetted material option C non-wetted material option C, pump option 0, 6 or 7, and kit option 0.

(3*)  II 2G EEx m c II T5
II 3/2 2G EEx m c II T5
II 2D c IP65 T100°C

 Note: Pumps ordered with the options listed in (1) to the left are ATEX compliant when ordered with kit option A1, A2, A3, or A4. Compressed Air Temperature Range: Maximum Ambient Temperature to plus 50°C.

(2)  II 2G Ex ia c IIC T5
II 3/2 G Ex ia c IIC T5
II 2D Ex c ia 20 IP67 T100°C

 Note: Pumps ordered with the options listed in (1) to the left are ATEX compliant when ordered with kit option P1.

(4)  IEC EEx m T4



 Note: Pump models equipped with these explosion-proof solenoid kit options E1, E3, E5, E7, E8 or E9, are certified and approved by the above agencies. They are **NOT** ATEX compliant.

**CAUTION! Operating temperature limitations are as follows:**

Maximum and Minimum Temperatures are the limits for which these materials can be operated. Temperatures coupled with pressure affect the longevity of diaphragm pump components. Maximum life should not be expected at the extreme limits of the temperature ranges.

Materials	Operating Temperatures	
	Maximum	Minimum
Nitrile General purpose, oil-resistant. Shows good solvent, oil, water and hydraulic fluid resistance. Should not be used with highly polar solvents like acetone and MEK, ozone, chlorinated hydrocarbons and nitro hydrocarbons.	190°F 88°C	-10°F -23°C
PVDF A durable fluoroplastic with excellent chemical resistance. Excellent for UV applications. High tensile strength and impact resistance.	250°F 121°C	0°F -18°C
NEOPRENE All purpose. Resistant to vegetable oils. Generally not affected by moderate chemicals, fats, greases and many oils and solvents. Generally attacked by strong oxidizing acids, ketones, esters, nitro hydrocarbons and chlorinated aromatic hydrocarbons.	200°F 93°C	-10°F -23°C
PTFE Chemically inert, virtually impervious. Very few chemicals are known to react chemically with PTFE: molten alkali metals, turbulent liquid or gaseous fluorine and a few fluoro-chemicals such as chlorine trifluoride or oxygen difluoride which readily liberate free fluorine at elevated temperatures.	220°F 104°C	-35°F -37°C
FKM (Fluorocarbon) shows good resistance to a wide range of oils and solvents; especially all aliphatic, aromatic and halogenated hydrocarbons, acids, animal and vegetable oils. Hot water or hot aqueous solutions (over 70°F) will attack FKM.	350°F 177°C	-40°F -40°C
Santoprene® Injection molded thermoplastic elastomer with no fabric layer. Long mechanical flex life. Excellent abrasion resistance.	275°F 135°C	-40°F -40°C
Polypropylene A thermoplastic polymer. Moderate tensile and flex strength. Resists strong acids and alkalis. Attacked by chlorine, fuming nitric acid and other strong oxidizing agents.	180°F 82°C	32°F 0°C

For specific applications, always consult the Warren Rupp "Chemical Resistance Chart"

CAUTION: Nonmetallic pumps and plastic components are not UV stabilized. Ultraviolet radiation can damage these parts and negatively affect material properties. Do not expose to UV light for extended periods of time.

Dimensions: S20 Non-Metallic

Dimensions in Inches [] in Millimeters
 Dimensional tolerance: +/- 1/8" [] +/- 3mm

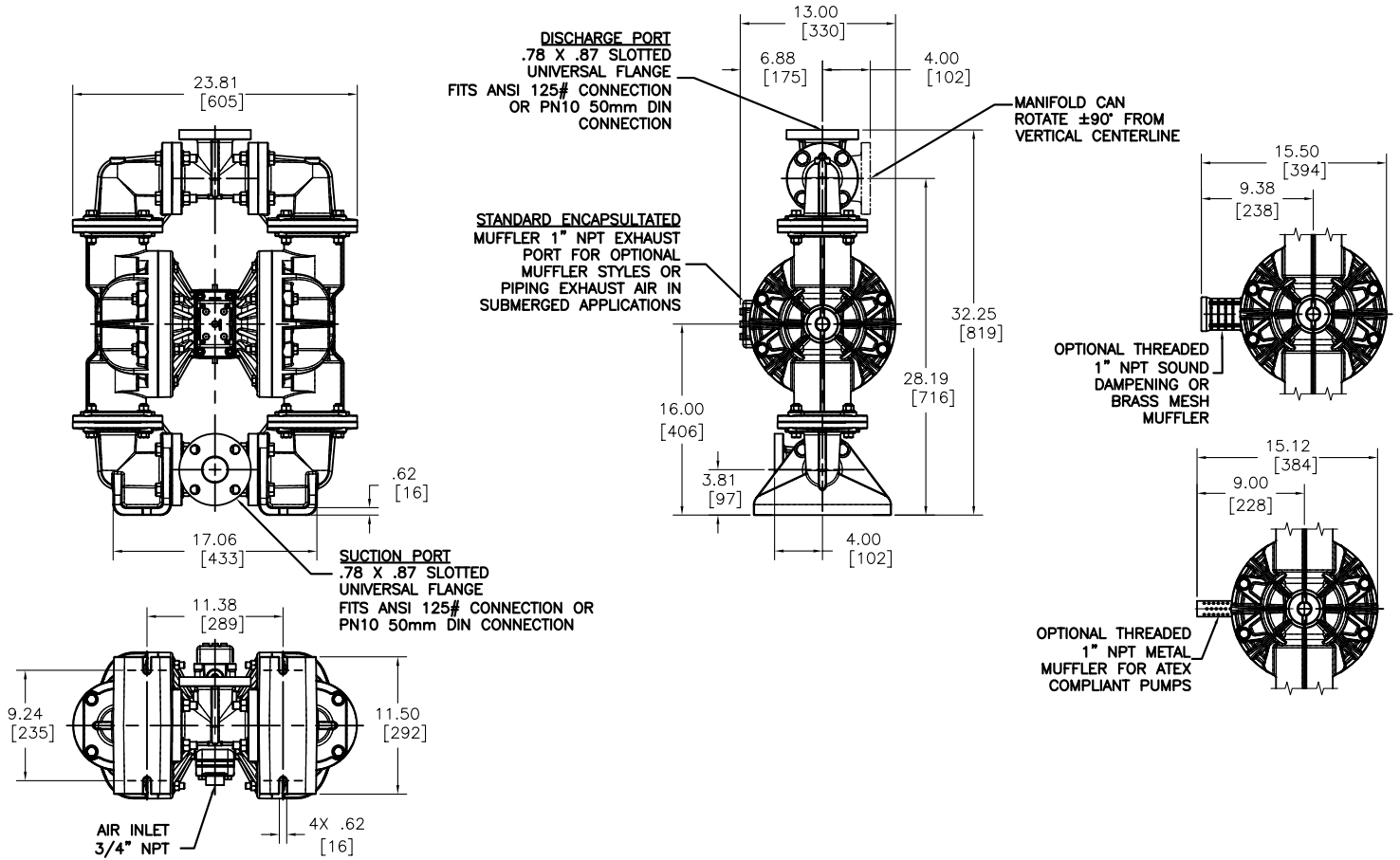

Dimensions: S20 Non-Metallic with Spill Containment

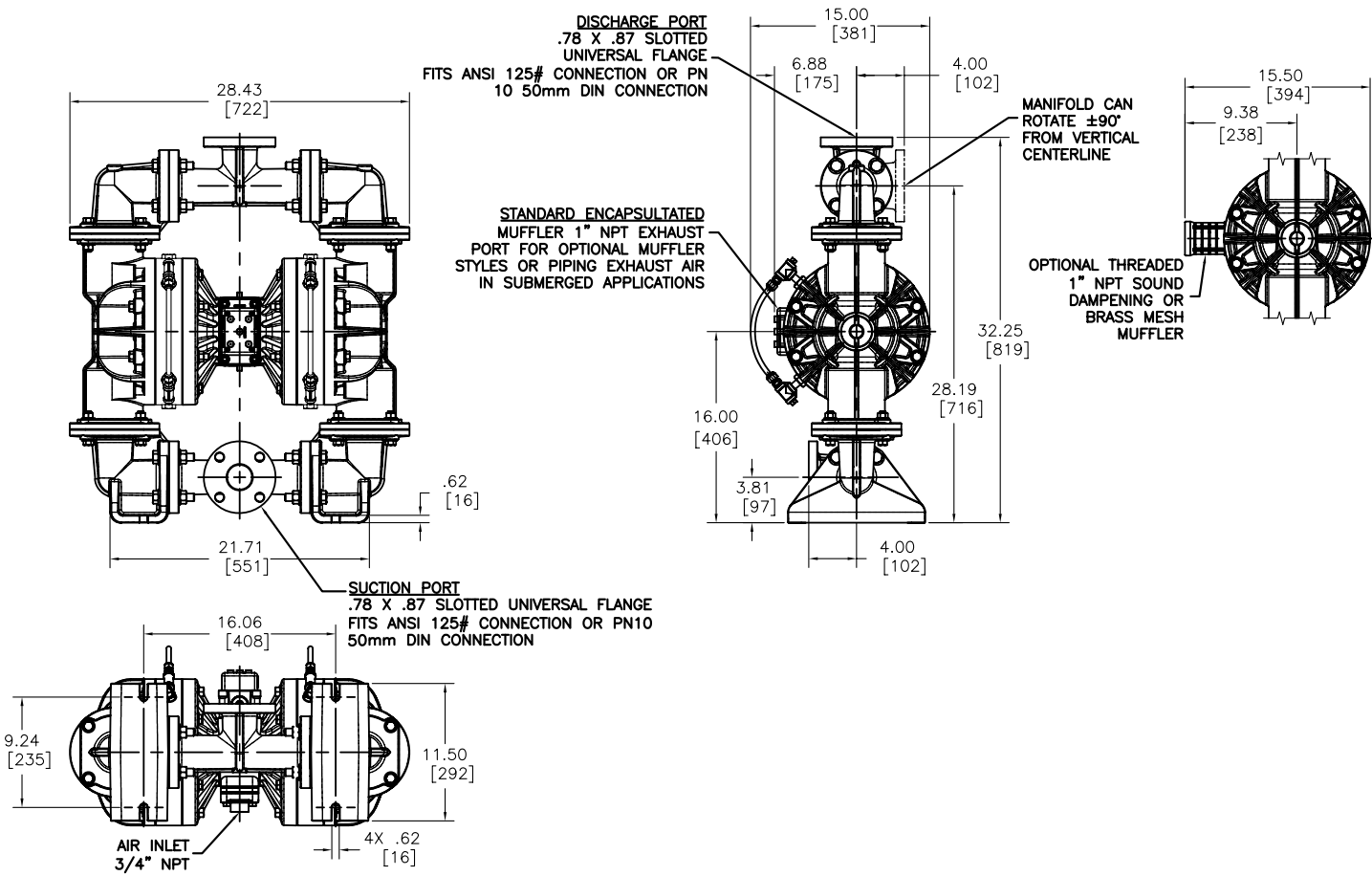

Declaration of Conformity

Declaration of Conformity

WARREN RUPP®

Declaration of Conformity

Manufacturer:

**Warren Rupp, Inc.®, 800 N. Main Street, P.O. Box 1568,
Mansfield, Ohio, 44901-1568 USA**

certifies that Air-Operated Double Diaphragm Pump Series: HDB, HDF, M Non-Metallic, S Non-Metallic, M Metallic, S Metallic, T Series, G Series, RS Series U Series, EH and SH High Pressure, W Series, SMA and SPA Submersibles, and Tranquilizer Surge Suppressors comply with the European Community Directive 2006/42/EC on Machinery, according to Annex VIII. This product has used Harmonized Standard EN 809, Pumps and Pump Units for Liquids - Common Safety Requirements, to verify conformance.

David Roseberry
Signature of authorized person

October 20, 2005
Date of issue

David Roseberry
Printed name of authorized person

Engineering Manager
Title

Revision Level: E

MAY 27, 2010
Date of revision



WARREN RUPP®

EC Declaration of Conformity

In accordance with ATEX Directive 94/9/EC,
Equipment intended for use in potentially explosive environments.

Manufacturer:

Warren Rupp, Inc.®
A Unit of IDEX Corporation
800 North Main Street
P.O. Box 1568
Mansfield, OH 44901-1568 USA

Applicable Standard:

EN13463-1: 2001,
EN13463-5: 2003



EN 60079-25: 2004

For pumps equipped with Pulse Output ATEX Option
KEMA Quality B.V. (0344)

AODD Pumps and Surge Suppressors

For Type Examination Designations, see page 2 (back)

AODD (Air-Operated Double Diaphragm) Pumps

EC Type Examination Certificate No. Pumps: KEMA 09ATEX0071 X

KEMA Quality B.V.
Utrechtseweg 310
6812 AR Arnhem, The Netherlands

SANDPIPER®
A WARREN RUPP PUMP BRAND

Tranquilizer®

DATE/APPROVAL/TITLE:
27 MAY 2010

David Roseberry
David Roseberry, Engineering Manager

IDEX
FLUID & METERING

WARREN RUPP®

EC Declaration of Conformity

ATEX Summary of Markings

Type		Marking	Listed In	Non-Conductive Fluids	
Pump types, S1F, S15, S20, and S30 provided with the pulse output option		II 2 G Ex ia c IIC T5 II 3/2 G Ex ia c IIC T5 II 2 D Ex c iaD 20 IP67 T100°C	KEMA 09ATEX0071 X CE 0344	KEMA 09ATEX0071 X KEMA 09ATEX0071 X KEMA 09ATEX0071 X	No Yes Yes
Pump types, S1F, S15, S20, and S30 provided with the integral solenoid option		II 2 G EEx m c II T5 II 3/2 G EEx m c II T5 II 2 D c IP65 T100°C	KEMA 09ATEX0071 X CE 0344	KEMA 09ATEX0071 X KEMA 09ATEX0071 X KEMA 09ATEX0071 X	No Yes Yes
Pump types, HDB1½, HDB40, HDB2, HDB50, HDB3, HDF1, HDF25, HDF2, HDF3M, PB¼, S05, S1F, S15, S20, S30, SB1, SB25, ST1½, ST40, G15, G20, and G30, without the above listed options, no aluminum parts		II 1 G c T5 II 3/1 G c T5 II 1 D c T100°C I M1 c I M2 c	KEMA 09ATEX0071 X KEMA 09ATEX0072 X CE 0344	KEMA 09ATEX0071 X KEMA 09ATEX0071 X KEMA 09ATEX0071 X KEMA 09ATEX0071 X KEMA 09ATEX0072 X	No Yes Yes No Yes
Pump types, DMF2, DMF3, HDB1½, HDB40, HDB2, HDB50, HDB3, HDF1, HDF25, HDF2, HDF3M, PB¼, S05, S1F, S15, S20, S30, SB1, SB25, SE½, ST1, ST25, ST1½, ST40, U1F, G05, G1F, G15, G20, and G30		II 2 G c T5 II 3/2 G c T5 II 2 D c T100°C	KEMA 09ATEX0072 X CE	KEMA 09ATEX0072 X KEMA 09ATEX0072 X KEMA 09ATEX0072 X	No Yes Yes
Surge Suppressors all types		II 2 G T5 II 3/2 G T5 II 2 D T100°C	KEMA 09ATEX0073 CE	KEMA 09ATEX0073 KEMA 09ATEX0073 KEMA 09ATEX0073	No Yes Yes

EC Type Certificate No. Pumps: KEMA 09ATEX0071 X

Type Certificate No. Pumps: KEMA 09ATEX0072 X

Type Certificate No. Suppressors: KEMA 09ATEX0073