

PW Series (PPG)

General Purpose Magnetic Drive Pumps

- PPG wetted-end material.
- 9 models with flow rates up to 1400 lit/min and discharge head of 37m.
- Able to handle many types of chemical and temperature of up to 70 °C.
- Adaptable to IEC Standard motor, 0.37 to 11kw.
- Available in flange connections.



Type indication

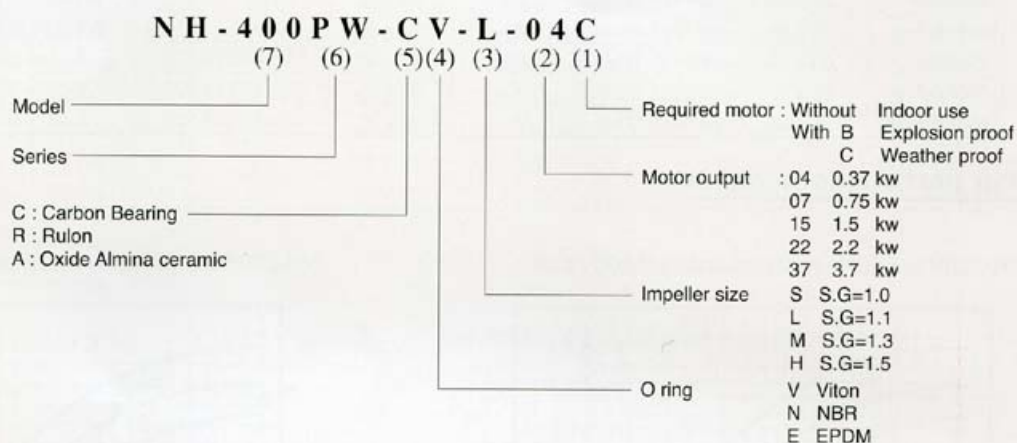

Specification table

Type	Flange size		Pump performance at specified point (M at L/min)			Applicable Motor output (KW)	Net weight (Kg)
	Outlet (mm)	Inlet (mm)	Specific Gravity	50Hz	60Hz		
NH-400PW	40A	40A	1.1	8.3 - 165	6.7 - 160	IEC 0.37kw	16
			1.3	7.0 - 155	7.8 - 140		
			1.5	6.1 - 130	5.9 - 130		
NH-401PW	40A	40A	1.1	12.0 - 240	11.5 - 250	IEC 0.75kw	23
			1.3	9.8 - 185	9.2 - 200		
			1.5	9.1 - 165	7.5 - 200		
NH-402PW	40A	50A	1.1	14.0 - 320	14.0 - 300	IEC 1.5kw	33
			1.3	14.0 - 280	13.9 - 265		
			1.5	12.0 - 280	14.5 - 220		
NH-403PW	40A	50A	1.1	20.0 - 310	19.0 - 280	IEC 2.2kw	37
			1.3	16.0 - 340	17.0 - 280		
			1.5	15.5 - 340	14.7 - 340		
NH-405PW	40A	50A	1.1	23.0 - 390	24.0 - 420	IEC 3.7kw	52
			1.3	21.1 - 400	24.0 - 390		
			1.5	19.0 - 390	20.0 - 390		
NH-655PW	65A	80A	1.1	15.0 - 700	15.5 - 600	IEC 3.7kw	110
			1.3	12.0 - 650	---		
			1.5	10.2 - 570	---		
NH-657PW	65A	80A	1.1	17.5 - 800	18.0 - 750	IEC 5.5kw	120
			1.3	17.6 - 630	16.5 - 630		
			1.5	15.3 - 620	13.3 - 760		
NH-6510PW	65A	80A	1.1	23.4 - 780	23.4 - 800	IEC 7.5kw	130
			1.3	22.7 - 640	19.6 - 770		
			1.5	17.5 - 800	18.1 - 670		
NH-6515PW	65A	80A	1.1	25.5 - 1040	29.5 - 1030	IEC 11.0kw	140
			1.3	25.5 - 1040	31.5 - 650		
			1.5	25.2 - 880	24.6 - 850		

Parts List

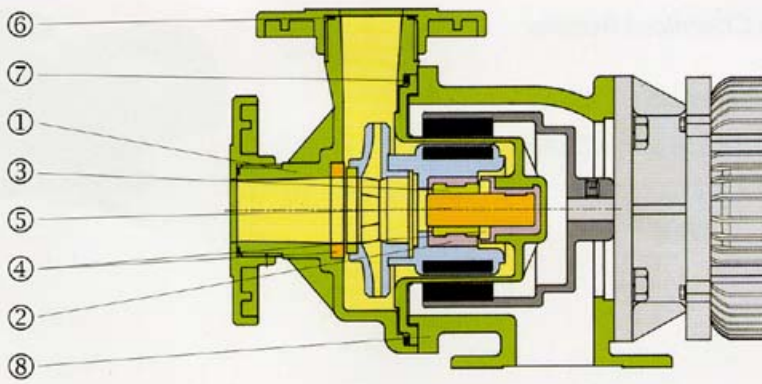

Part name	PW Series				
	CV	RV	AV	CN	AN
1. Casing	PPG				
2. Holder	PPS				
3. Bearing	Carbon	Rulon	Ceramic	Carbon	Ceramic
4. Thrust pad	Ceramic				
5. Spindle	Ceramic				
6. O ring	FKM		NBR		
7. O ring	FKM		NBR		
8. Bracket	Grey cast iron				

PW series performance curve

